

Effat University Repository

Comparative analysis of maximum power point tracking methods for power optimization in grid tied photovoltaic solar systems

Authors	Elsaf, Abubakar;m A. Almohammed, Akram;Balfaqih, Mohammed;Balfagih, Zain;Sabri, Saeed
Citation	Isafi, A., Almohammed, A.A., Balfaqih, M. et al. Comparative analysis of maximum power point tracking methods for power optimization in grid tied photovoltaic solar systems. Discov Appl Sci 7, 976 (2025). https://doi.org/10.1007/s42452-025-07606-w
DOI	https://doi.org/10.1007/s42452-025-07606-w
Publisher	Springer International Publishing
Rights	CC0 1.0 Universal
Download date	2026-04-17 22:17:06
Item License	http://creativecommons.org/publicdomain/zero/1.0/
Link to Item	https://repository.effatuniversity.edu.sa/handle/20.500.14131/2260

RESEARCH

Open Access



Comparative analysis of maximum power point tracking methods for power optimization in grid tied photovoltaic solar systems

Abubakar Elsafi¹, Akram A. Almohammed², Mohammed Balfaqih³, Zain Balfagih⁴ and Saeed Sabri^{5*}

*Correspondence:

Saeed Sabri

Sabri.alshibany@just.edu.ye

¹Department of Software Engineering, College of Computer Science and Engineering, University of Jeddah, Jeddah, Saudi Arabia

²Electrical and Electronics Engineering Department, Karabük University, Karabük, Turkey

³Department of Computer and Network Engineering, University of Jeddah, 23218 Jeddah, Saudi Arabia

⁴Computer Science Department, Effat Energy and Technology Research Center, Effat College of Engineering, Effat University, 34689 Jeddah, Saudi Arabia

⁵Department of Network and Cyber Security, Aljanad University for Science and Technology, Taiz, Yemen

Abstract

The accelerating global shift toward renewable energy sources is largely attributed to increased investments and the rising demand for electricity, driven by technological progress, population growth, and escalating fuel prices associated with traditional power generation. Despite their benefits, conventional energy systems face challenges such as sensitivity to fluctuations in solar irradiance and temperature, which lead to non-linear electrical behavior and reduced efficiency. In Iraq, for example, the World Bank reports a significant power distribution loss of approximately 51%. To mitigate these inefficiencies, this study introduces a grid-connected photovoltaic (PV) system employing Maximum Power Point Tracking (MPPT) techniques—specifically, the Perturb and Observe (P&O) and Incremental Conductance (I&C) algorithms. These approaches aim to enhance energy extraction from PV arrays under dynamic environmental conditions. System modeling and performance evaluation were conducted using MATLAB/Simulink, focusing on optimizing output and regulating the DC–DC boost converter's switching frequency. Under varying irradiance (1000–250 W/m²) and temperature (25–50 °C) conditions, I&C algorithm achieved a higher MPPT tracking efficiency of approximately 98.7%, compared to 95.2% for the P&O method. Additionally, I&C demonstrated faster convergence with a response time of 0.15 s and exhibited reduced power ripple (~1.2 kW) versus P&O (~3.8 kW), confirming its superior dynamic stability and steady-state performance.

Article highlights

A smart solar system setup was tested to see which method extracts energy more efficiently from sunlight.

One method (I&C) provided faster and more stable power performance, especially under changing weather conditions.

The results can help guide future solar system designs, especially in areas with hot climates like Iraq.

Keywords I&C, MPPT, P&O, Photovoltaic system (PV), Renewable energy



1 Introduction

Iraq's energy demand has risen significantly in recent years due to population growth, industrial development, and improved living standards. However, the destruction of nearly 90% of the power infrastructure during the 1991 Gulf War, coupled with ongoing issues such as sabotage, corruption, and inadequate transmission control, has hindered full recovery. Despite partial restoration, the power sector continues to fall short of meeting national demand, with consumption projected to increase by 70% to close the supply gap [1, 2]. In addition, Iraq experiences extreme and variable environmental conditions, including temperatures that frequently exceed 50 °C and fluctuating solar irradiance, which significantly affect photovoltaic system performance. Unlike many regions where standard test conditions apply, these harsh environments present real-world challenges that can degrade system stability and power output. Studying MPPT methods under these conditions is therefore essential to ensure accurate tracking, efficiency, and reliability in local PV deployments. Additionally, insights from this work are transferable to other high-temperature regions such as Kuwait, Saudi Arabia, and parts of North Africa, making the research contextually and regionally relevant.

Solar energy has been a subject of interest for researchers due to its accessibility, low cost, and eco-friendly, non-polluting, and non-exhaustive nature [3, 4]. Solar energy is generated by shining light from the sun on semiconductor-coated panels, which in turn produces electrical power [5]. The electrical output of the panels is determined by two factors: solar radiation intensity and temperature [6]. Consequently, their electrical characteristics are not linear, making the photovoltaic (PV) systems less efficient [7]. To convert clean power into various types of energy, it is essential to accurately measure solar irradiance on the spot and understand its properties [8]. However, enhancing the efficiency of solar panels and inverters is a difficult task, and production is limited by technology. Additionally, higher-performance components may be required for the system's structure, resulting in significantly higher operational costs [9]. To resolve the issue of low output from solar panels and the impact of changing light intensity and temperature on them, several strategies have been developed to regulate the charge and monitor the Maximum Power Point (MPP). These strategies are collectively referred to as Maximum Power Point Tracking (MPPT) systems, which enable the panels to produce the maximum power even when the weather changes [10–12].

Recent studies [3, 13–19] have conducted a comprehensive review and discussed different types of MPPT algorithms in solar PV systems, their advantages, and disadvantages, and how they affect the output of a photovoltaic system. Moreover, a comparative analysis of different MPPT techniques, and recommendations for future research have been presented. The most common MPPT approaches are Fuzzy Logic Control (FLC), Perturb and Observe (P&O), and incremental conductance (IncCond). In [20], authors have explored both P&O and IncCond approaches and suggest updated versions to address their ineffectiveness. To reduce costs and streamline the process, the PV panel can be directly linked to the inverter without the DC–DC converter. A DC–DC boost converter and MPPT for PV systems based on predictive IncCond was developed in [21]. The findings indicated that developed IncCond was superior to the conventional IncCond algorithm, with reduced power ripple. Typical MPPT methods were used to investigate different converter layouts for a PV system, such as P&O method with adaptable step sizes, continued improvement of IncCond, and a new IncCond method [22].

These algorithms compared static and dynamic irradiance while accounting for MPP variations, track speed, and detection characteristics.

In addition to the technical issues, the development of PV systems faces other challenges depending on the targeted geographical locations including financial, political, environmental, and governmental challenges [23]. This attracted the researchers to investigate these challenges in different regions and countries including Iraq [24–32]. Although several research works investigated different aspects of PV systems in Iraq, further research is required to optimize the design and performance of the system for larger-scale applications with the consideration of different environmental or socio-economic conditions. Accordingly, a new PV system based on MPPT is designed and evaluated under a variety of measuring circumstances. The solutions obtain the greatest amount of power from photovoltaic panels beneath a variety of measuring circumstances. MATLAB/Simulink is employed to evaluate MPPT to identify maximum output and manage the operating frequency of a DC–DC boost converter. Unlike many previous MPPT studies that focus solely on PV system behavior under standard test conditions or basic grid connection models, our work uniquely integrates a full-scale grid-connected PV system with a 132 kV high-voltage transmission bus, representing a realistic utility-level scenario. This configuration, which includes a variable speed converter (VSC) and synchronization with a three-phase transmission line, is rarely addressed in comparable MPPT simulations. It allows for detailed analysis of how classical algorithms such as P&O and I&C perform under utility-scale constraints and variable environmental conditions relevant to Iraq and similar regions.

The main contributions of the manuscript can be concluded as follows,

- *Development of a high-voltage grid-connected photovoltaic (PV) system model* that integrates a PV array, DC/DC boost converter, MPPT controller, inverter, and VSC connected to a 132 kV three-phase transmission bus. Unlike many existing studies that focus on low-voltage or standalone systems, this work simulates a realistic utility-scale infrastructure with minimal load connections and full synchronization with a national grid. In Iraq, the 132 kV transmission level is one of the most commonly used voltage levels for sub-transmission in the national grid. Many substations and industrial feeders operate at this level, making it a realistic and relevant integration point for utility-scale PV systems. Thus, modeling the PV system connection to a 132 kV bus provides a practical framework that reflects actual grid interconnection practices in Iraq and enhances the relevance of the proposed simulation.
- *Comprehensive performance comparison between classical MPPT algorithms (P&O and Incremental Conductance)* within a high-voltage grid context. The study evaluates their behavior in terms of tracking efficiency, power ripple, convergence time, and duty cycle stability—under dynamically varying irradiance and temperature conditions representative of Iraq's environment.
- *Quantitative analysis of the system's response to real-world environmental disturbances*, highlighting how temperature and irradiance transients affect voltage-current (I–V) and power-voltage (P–V) characteristics. This allows for accurate assessment of algorithm robustness and system stability in non-ideal deployment regions.
- *Identification of operational trade-offs between the algorithms*, demonstrating that while P&O suffers from oscillations near the MPP, the I&C method provides

smoother convergence and better response under irradiance fluctuations. These insights offer practical guidelines for selecting appropriate MPPT strategies in utility-scale PV deployments.

The rest of the paper is structured as follows: Sect. 2 discusses the existing works in designing, developing, and evaluating PV system in Iraq. Section 3 details the materials and methods including the PV model, boost converter, MPPT controller, Inverter, Voltage source converter, 132 kV Grid, and Simulink model. Section 4 discusses the results. Finally, the paper is concluded in Sect. 5.

2 Related works

The challenges of developing PV systems in Iraq are represented by a variety of barriers, including technical, environmental, and economical types. This section discusses the existing studies in designing and improving PV systems in Iraq. The studies could be categorized based on their scope and addressed development challenge into economical [24, 25], and design and operation [26–33].

Few studies in the literature investigated the economic feasibility of PV systems in Iraq. In [24], the study identified the best location for PV plant installation, evaluated the viability of proposed plants, and compared the performance of a fixed and double-axis tracking system. A 10 MW PV plant was developed and simulated based on economic terms using simulation software to model and analyze performance and economic feasibility in three different locations. The study concluded that PV power plants can be a viable solution to address inadequate power supply in Kurdistan, while acknowledging limitations such as limited data availability on solar radiation intensity and lack of consideration for other renewable energy sources.

The authors in [25] presented a technical and economic feasibility analysis of a grid-connected PV solar system installed at a university campus in Iraq. This is to generate electricity and reduce reliance on traditional energy sources. To evaluate the feasibility of this solution, the authors conducted a technical–economic study using software tools such as PVsyst and HOMER Pro. Data on solar radiation, temperature, and other relevant factors from weather stations located near the university campus were collected and analyzed by calculating performance ratio, capacity factor, cost of energy, and yield factor. The results demonstrated that the investment in PV technology is favorable in this site, as the proposed PV system could generate 1.5 GWh/year with an annual saving of \$150,000 USD compared to traditional energy sources. The study also highlighted that performance ratio and capacity factor are important factors that affect the productivity of PV systems.

On the other hand, for design and operation, numerous technical barriers to the implementation of solar photovoltaic power generation in Iraq have been discussed in [26]. One of the most important technical issues is the connection of smart meters in the grid, which perform essential and major tasks whereas the consumer can control the electrical loads, prevent it from overrunning the electrical grid and monitoring the consumer by connecting these meters to the control units. Other technical barriers may include issues with power generation on both the electricity side and demand side. A PV system design software has been developed in [27], that accommodates Iraq's unique conditions. This software includes features such as electrical drawing, customizable design parameters based on the designer's information and the average irradiation

at the installation location, designing and analyzing off-grid PV systems, real-time notification of any problem with the designed PV system, and reverse design. The authors tested their proposed solution by designing an off-grid PV system at the Ministry of Science and Technology in Baghdad using the new software. Experimental results were then compared to theoretical results obtained from the software, demonstrating that the program was both accurate and reliable. However, the study only focused on off-grid and may not be applicable to other regions or grid-connected systems.

In [28], the authors focused on addressing the lack of reliable electricity in rural areas of Iraq by implementing a grid-connected PV system for a resident in Al-Najaf. The proposed solution involves using solar energy to generate electricity that can be fed into the local power grid. Implementation of the system involved several steps, including site assessment, system design, equipment procurement and installation, and commissioning. The findings show that the PV system successfully provided reliable electricity to the rural residents in Al-Najaf, improving quality of life and contributing to economic development. However, the study focused on only one rural resident in one specific location in Iraq and the uncertainty of whether similar results could be achieved in other areas with different environmental or socioeconomic conditions.

The authors in [29] designed and analyzed the performance of a stand-alone PV system at Nahrain University in Baghdad. The proposed solution involved designing and simulating a stand-alone PV system that can generate electric power independently, divided into two cases to analyze the shading effect of trees. The results illustrated that the proposed stand-alone PV system can generate electric power independently with high efficiency, but the study's limitations include focusing on one specific location and not considering other factors such as maintenance costs or environmental impacts.

Selecting a suitable location for the solar cell is critical to generate electricity from solar energy and to determine the duration of exposure to the sun's rays, while losses that occur during the conversion of light energy to electrical energy can decrease the efficiency of the solar cell. Hence, the study in [30] focused on calculating losses and identifying the optimal location for the solar cell, leading to higher efficiency. The implementation involved applying the PV simulation system to install a solar cell on a house roof and determining the ideal installation location and height that the selection of an appropriate location for the solar cell is crucial to increase its efficiency, and the simulation program can determine optimal solutions to avoid the shadow effects on efficiency.

An off-grid hybrid system that combines PV, Biomass, and Hydroelectric Pumped Storage technologies has been proposed in [31] to address the issue of isolated load in remote or rural areas of Iraq. The Atom Search Optimization (ASO) algorithm is utilized to determine the optimal configuration of the system based on real-time load demand and meteorological data, with the goal of achieving the minimum Net Present Cost (NPC) for the whole system. The findings indicated that this off-grid hybrid system is a feasible alternative to traditional diesel generators, with potential economic benefits and reduced environmental impact. However, implementing such type of energy system faces several challenges, such as limited availability of biomass resources and high initial investment costs.

The study in [32] designed and analyzed the performance of an on-grid PV system that can work in parallel with the local grid to supply household appliances or feed excess energy back into the grid. The implementation of the system included a PV array with

MPPT algorithm, a boost converter, an inverter, and an LC filter. The results showed that the proposed on-grid PV power system is a feasible solution to meet energy demands in Iraq, as it can operate without storage units and supply excess energy to the grid. The MPPT algorithm improves the efficiency of the solar system, while voltage and current mode controllers stabilize load voltage based on grid requirements. However, this study only considered one location in Iraq and doesn't account for variations in weather conditions across different regions. It can be observed from the literature that further research is required to optimize the design and performance of the system for larger-scale applications with the consideration of different environmental or socioeconomic conditions.

Several recent studies have investigated MPPT techniques to enhance the performance of photovoltaic systems under dynamic environmental conditions. In [34], the authors presented a comparative study of classical MPPT algorithms including P&O and I&C under varying irradiance profiles. Their results highlighted the impact of environmental fluctuations on tracking accuracy; however, the study was limited to a low-voltage standalone system without grid integration. Similarly, an artificial neural network-based MPPT controller was proposed in [35] that demonstrated improved adaptability to irradiance and temperature variations. While the findings were promising, the work lacked experimental validation and did not consider high-voltage or grid-connected setups. In [36], a hybrid MPPT algorithm combining fuzzy logic with P&O was introduced to enhance dynamic tracking response. Although the method achieved faster convergence to the MPP, the study was conducted in a controlled simulation environment and did not include system-level interactions such as inverter performance or utility grid synchronization. These studies underscore the importance of robust MPPT strategies but highlight gaps in full-system modeling and grid-level applicability.

Recent advancements in MPPT techniques emphasize enhanced accuracy and robustness under dynamic environmental conditions. Siddique et al. [37] provided a comprehensive review of emerging MPPT algorithms, highlighting the integration of AI-based approaches such as artificial neural networks (ANN), fuzzy logic, and swarm intelligence to improve adaptability and efficiency. Several studies proposed optimization-based model predictive control variants, including APO-MPC and EMPC, which were validated through MATLAB/Simulink and real-time datasets [38–41]. These methods demonstrated superior performance in tracking the global MPP, particularly under partial shading and load variations, achieving over 99% efficiency with sub-second convergence times. However, limitations persist regarding computational complexity and dependence on extensive sensor inputs.

Complementing these trends, recent research has introduced hybrid and real-time implementable MPPT strategies. For instance, Belghiti et al. (2024) proposed an adaptive Fractional Open-Circuit Voltage (FOCV) technique integrated with an Improved Model Reference Adaptive Controller (IMRAC), validated using Processor-in-the-Loop (PIL) testing on Arduino, achieving a tracking efficiency of over 99.49% under variable irradiance [42]. Similarly, a CNN-assisted MPPT framework implemented on FPGA hardware demonstrated highly efficient real-time power optimization under fast-changing weather conditions [43]. In another study, a combination of bio-inspired methods—such as hybrid whale and gray wolf optimization—with fuzzy logic was used to enhance convergence and minimize steady-state oscillations [44]. While these approaches show strong potential, they may increase system complexity and require significant computational

resources. By contrast, the current study focuses on the comparative analysis of classical MPPT algorithms (P&O and I&C) under realistic utility-scale simulation conditions, providing a reliable baseline for future research involving hardware prototypes and AI-integrated controllers.

The study by Jatly and Arora (2018) in [45] presented a comparative investigation of classical and modified hill-climbing MPPT algorithms—including P&O, INC, and INR—under rapidly changing irradiance and temperature conditions using MATLAB/Simulink. While their simulation showed that modified variable-step-size algorithms outperform conventional ones in dynamic and steady-state responses, the work lacks grid integration and does not address high-voltage transmission conditions. Similarly, the study by Jatly et al. (2021) in [46] offered an experimental comparison of hill-climbing MPPT methods, focusing on performance under low irradiance. However, this work is limited by its focus on low-power setups without considering system-level grid-connected behavior or regional environmental conditions such as those in Iraq.

While prior studies have explored PV system feasibility and design across various configurations in Iraq, most are limited in scope—focusing on single-site case studies, off-grid setups, or general design tools without integrating real transmission networks. Few incorporate MPPT algorithm comparisons or consider the impact of Iraq’s high-temperature and irradiance fluctuations on system stability. This study addresses these gaps by designing and simulating a grid-connected PV system integrated with a 132 kV transmission line under dynamic environmental conditions, comparing classical MPPT algorithms (P&O and I&C) through quantitative metrics, and analyzing ripple effects and convergence behavior. This comprehensive approach offers a more realistic and scalable framework for PV integration in Iraq and similar regions. To better understand the landscape of PV design and control strategies in Iraq, Table 1 summarizes several studies that implemented or analyzed PV systems with MPPT techniques, highlighting their scope, control methods, and system types.

Table 1 Summary of PV system design and MPPT methods in Iraq-related studies

Study	Scope	MPPT Algorithm	Grid Integration	Limitation
Abed, et al. [27]	Design software for off-grid PV	None	Off-grid	Only for off-grid; lacks hardware testing
Al-akayshee, et al. [28]	Rural PV system deployment	None	Grid-connected	Case-specific; lacks generalization
Mahmood, [30]	Optimization of solar cell placement	None	Standalone	Focused on installation angle; no full system modeling
Endiz, [34]	Robust MPPT under partial shading and temperature change	Fuzzy Logic + P&O	Grid-connected	Simulated only; does not include utility-scale grid connection
Alsulami, et al. [35]	Optimization of solar cell placement	None	Standalone	Focused on installation angle; no full system modeling
Thanh, et al. [36]	AI-enhanced MPPT performance under fluctuations	Hybrid ANN + I&C	Microgrid	High computational load; hardware not implemented
Jatly and Arora, [45]	Experimental analysis of various MPPT techniques	P&O, I&C, Hill Climbing	Stand-alone system	Focus on irradiance sensitivity, lacks real-time control aspects
Jatly et al. [46]	Performance investigation of MPPT under varying irradiance and temperature	P&O, I&C, Hill Climbing	Not grid-connected	Limited to low irradiance, no grid simulation
Our study	Grid-connected PV with 132 kV transmission line	P&O and I&C	Simulated 132 kV grid	No hardware validation; simulation-based only

3 Materials and methods

The system is proposed to measure the maximum output power could be achieved for Iraq and any other regions with similar environmental situations that does not suit with ideal PV system. The environmental conditions of Iraq witnessed a high temperature degree reaches to 50 °C like other countries such as Kuwait, and Saudi. The proposed PV system consists of solar panels which will then be fed into a DC–DC boost converter to ensure a constant voltage source of 500 V. The primary purpose of the photovoltaic panel is the conversion of light into energy via the photo-voltaic mechanism, with no negative effects on environmental degradation or annoying noise [47]. The system includes PV, a DC/DC boost converter controlled by a pulse width modulation (PWM) signal, a MPPT controller that uses the PV module's currents and voltages to optimize power extraction, an inverter that transforms DC into AC, VSC controller that generates electrical pulses for the inverter that is connected to a 132 kV bus and some loads. Figure 1 shows a schematic diagram of grid-connected PV solar system using MPPT based P&O Algorithm.

As the study is based solely on simulation, care was taken to ensure model accuracy and reliability. The photovoltaic module (SunPower SPR-305E-WHT-D), boost converter, and grid components were modeled using well-established equations and validated Simulink blocks that replicate real-world behavior. Additionally, the simulation outputs were cross-verified against the standard performance curves of the PV module and against benchmark studies in the literature to ensure consistency and correctness of results. The following sub-sections describe the components of the PV system.

3.1 PV module

The primary purpose of a PV cell is to transform light into electrical power without causing noise, pollution, or harming the environment [48]. The resistances of PV cells form a group of solar panels that can be connected in parallel or series. Unlike traditional solar cells, they are embedded and combined with the photovoltaic diode in practical applications. When initially installed, the PV system functions as a current source, but its behavior changes as the voltage on its terminals approach the open circuit value, making modeling challenging. Figure 2 displays the PV module's circuit.

The following are the list of the equations that can be derived from the circuit analysis:

$$I = I_{ph} - (I_d + I_{sh}) \tag{1}$$

$$I_{ph} = (I_{scr} + k_i \Delta T) \frac{G}{G_c} \tag{2}$$

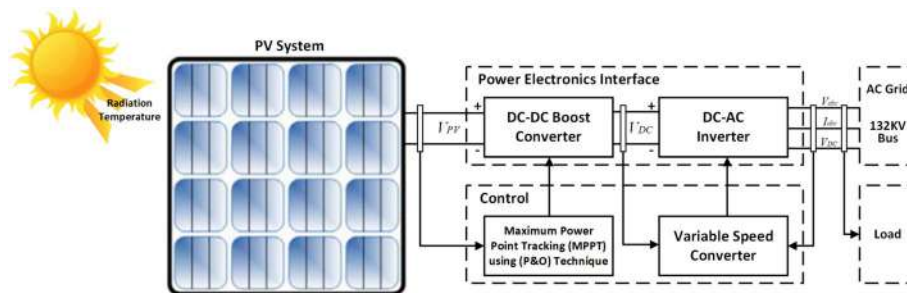

Fig. 1 A schematic diagram of grid-connected photovoltaic solar system using MPPT based perturb and observe algorithm

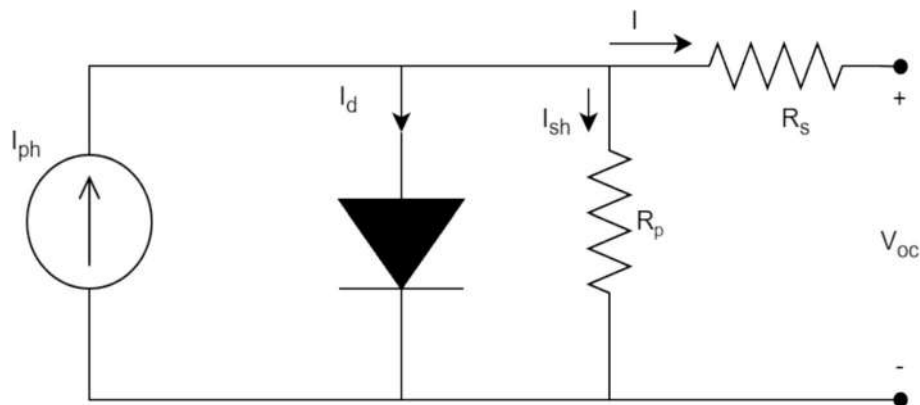

Fig. 2 PV's circuit model

$$I_o = I_{rs} \left(\frac{T}{T_{ref}} \right)^3 \exp \exp \left[\left(\frac{qE_{Gc}}{AK} \right) \left(\frac{\Delta T}{T_{ref}T} \right) \right] \quad (3)$$

$$I_{pv} = I_{ph} - I_o \left[\exp \exp \left(\frac{q(V_{pv} + I_{pv}R_s)}{AKT} \right) - 1 \right] - \frac{V_{pv} + I_{pv}R_s}{R_p} \quad (4)$$

where I_{pv} is incident light generated current, I_o is leakage or reverse saturation current of a diode, R_s is equivalent series resistance, R_p is equivalent parallel resistance, N_{ser} is cells in series, N_{par} is cells in parallel, and V_t is thermal voltage of an array. Due to the extreme complexity of the model's mathematical representation, explicit relationship of Terminal current and voltage is not feasible. The software allows us to analyze Terminal voltage (V) against Power (P) and Current (I) to understand the behavior. Voltage and current are sensitive to changes in environmental heat and light. To determine PV module performance under test conditions, it will be exposed to different levels of irradiance (i.e., 0.5, 1, 1.5, 2 kW/m²) at 25 °C.

The employed array type is SunPower SPR-305E-WHT-D with 5 series modules, and 66 parallel strings. The selection of the PV array configuration comprising 5 series-connected modules and 66 parallel strings was driven by the system's electrical and environmental requirements. Specifically, five modules in series were chosen to achieve a nominal voltage level suitable for the DC–DC boost converter's input, aligning with the MPP voltage range of approximately 270–300 V. Simultaneously, 66 parallel strings were selected to deliver the desired output power level (approximately 100 kW) while maintaining current values within the safe operating limits of the converter and inverter components. This configuration also ensures robustness against partial shading and thermal variations, which are common in high-temperature regions like Iraq. The design strikes a balance between voltage, current, and total power to meet the system's operational and grid integration specifications.

Under these circumstances, Fig. 3 shows the relation between the current and the voltage (I–V curve), while Fig. 4 shows the relation between the power and the voltage (P–V). The figures shows that the current is constant over a large range of voltage, while the power increases linearly with voltage. Considering that peak power is the optimal operating point for a solar system, greater irradiation is beneficial since the optimum power rises with it.

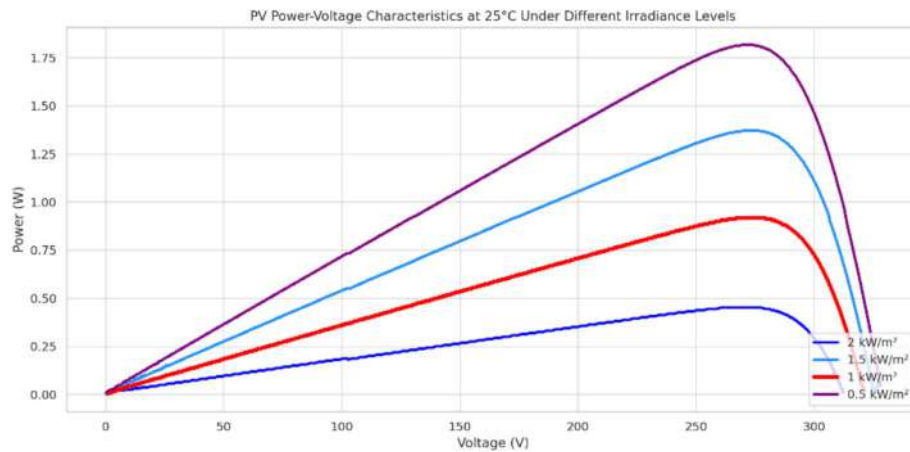

Fig. 3 The relation between the power and the voltage of the PV system under 25 °C and different irradianc levels

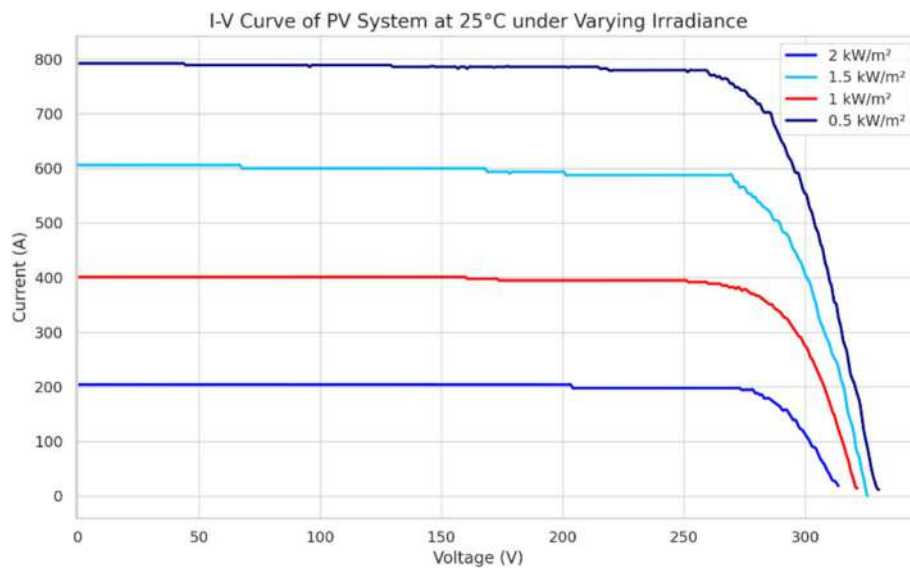

Fig. 4 The relation between the current and the voltage of the PV system under 25 °C and different irradianc levels

Moreover, temperature influences maximum power in which temperature increment decreases the maximum power. Therefore, excessive temperature is detrimental to the system. It is recognized that optimal operating temperature was 25 °C. This phenomenon is depicted in Figs. 5 and 6.

3.2 Boost converter

The DC/DC boost converter is used to regulate the power output from the Photovoltaic modules by boosting the voltage above the voltage source. In the boost converter circuit seen in Fig. 7, the transistor is driven by a square wave of a constant frequency, the amplitude of which is determined by the duty cycle (D).

Boosting the input voltage is controlled by the duty cycle of the square wave that drives the MOSFET transistor acting as the switch. This mathematical implication is as follows [49]:

$$V_{out} = V_{in}/(1 - D) \quad (5)$$

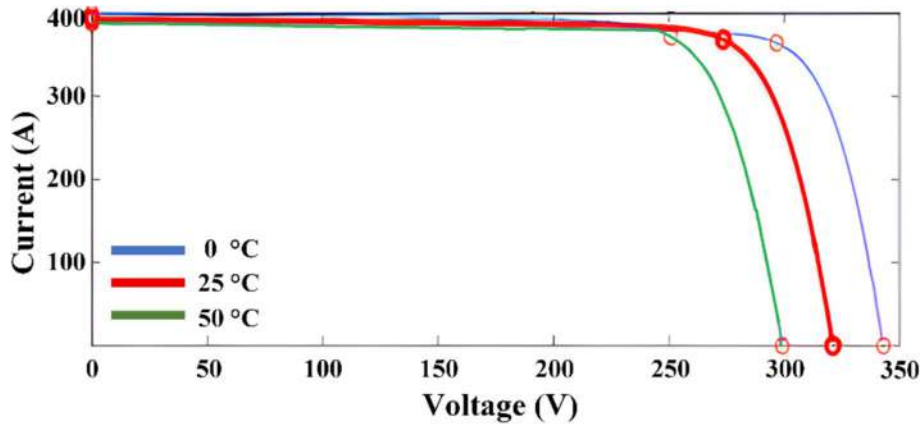

Fig. 5 The relation between the current and the voltage (I–V curve) of the PV system under 1000 W/m² and different temperature

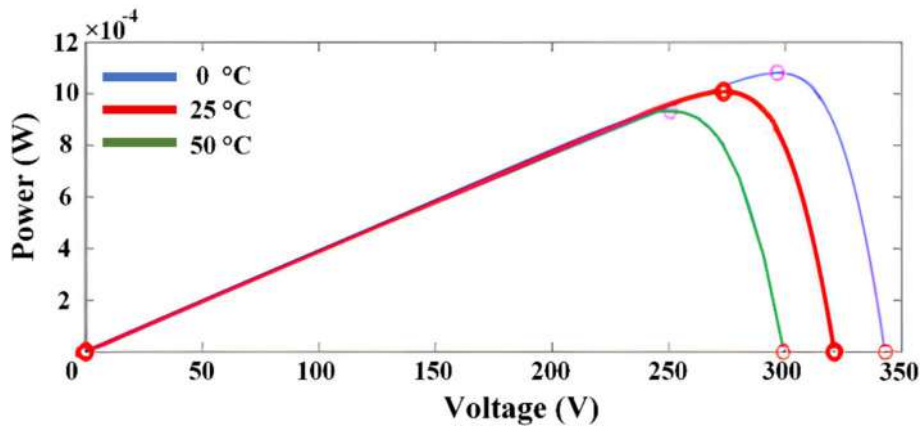

Fig. 6 The relation between the power and the voltage (P–V curve) of the PV system under 1000W/m² 1000 W/m² and different temperature

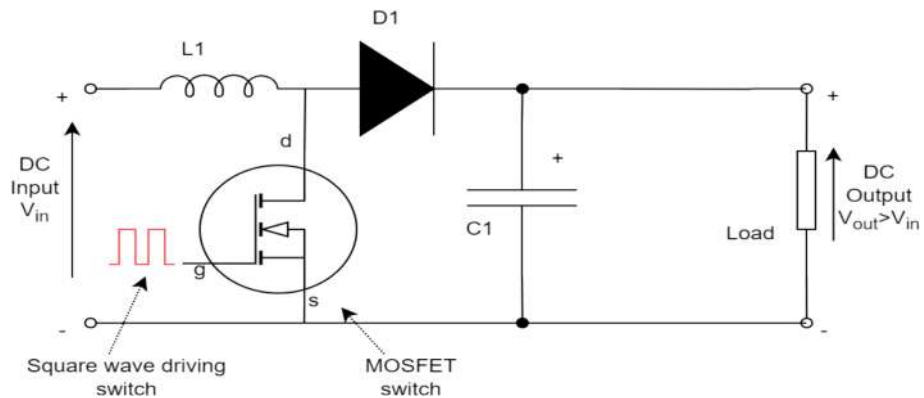

Fig. 7 DC/DC circuit of boost converter

where $D=0$ represents the 0% duty cycle, while $D=1$ represents the 100% duty cycle. Finding optimal settings for the inductor, capacitors, and square wave frequency is the primary challenge in constructing a boost converter. The circuit's wastage increases as the frequency increases, so it's best to use the lowest possible frequency to reduce costs.

To ensure stable and efficient voltage boosting, the boost converter was designed with a 5 mH inductor and a 24 mF output capacitor, operating at a switching frequency of 5 kHz. These values were selected to elevate the PV module's MPP voltage (approximately 273 V) to a constant 500 V DC bus voltage, while ensuring robust performance under varying environmental conditions. The inductor value maintains continuous conduction mode with ripple current below 10%, and the capacitor limits output voltage ripple to ± 5 V, improving inverter stability. The 5 kHz switching frequency offers a practical balance between fast MPPT response, manageable switching losses, and realistic component sizing for medium-scale systems. This configuration, verified through iterative simulation, results in a duty cycle of approximately 45.5%, optimized for high-temperature regions such as Iraq.

3.3 MPPT controller

Several algorithms have been developed to monitor the MPP. These approaches can be categorized based on their complexity, required observations, cost, and monitoring speed. The effectiveness of a methodology may vary depending on the application. The next sub-sections discuss the algorithms that will be considered in the study.

- Perturb and Observe (P&O) Algorithm

The maximum power point tracker (MPPT controller) acts as the system's central processing unit (CPU). This controller implements the algorithm necessary to follow the I–V and P–V curves shown in Figs. 5 and 6, respectively. The P&O method, also known as Hill climbing technique shown in Fig. 8, is used in the system.

The PWM signal used to gate the transistors in a Boost converter has a duty cycle of D . The algorithm's execution has two metrics to track: measuring the terminal voltage and current to determine the power consumption of the PV module, and adjusting

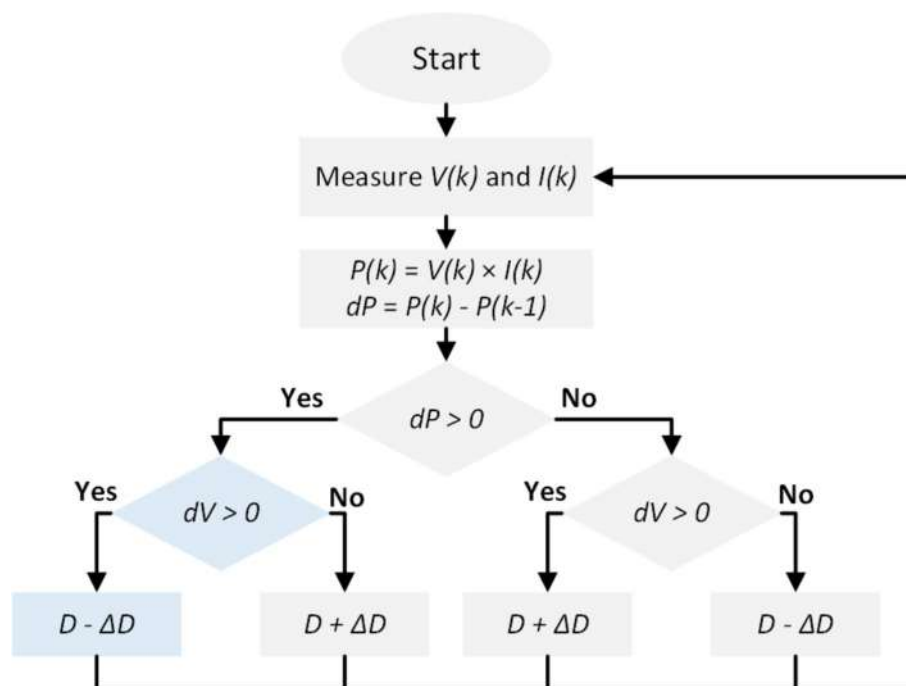

Fig. 8 P&O algorithm

D accordingly based on the parameters. The PV and IV curves are crucial aspects of this approach. However, there is a problem with drift in this algorithm when there is an abrupt shift in available light. Ideally, the algorithm should proceed steadily toward the limit, but when there is a fast fluctuation in irradiance, it deviates from the maximum level towards open-circuit voltage. An example of drift incidence is shown in Fig. 9 [50, 51].

Figure 8 highlights the situation causing the drift with light blue color in the left corner. The drift occurs with an abrupt change in irradiance, such as at sunrise. The power is highly sensitive to drift because the PV curve decreases rapidly after the maximum point, leading to a significant decrease in power if the drift happens. Therefore, we must adjust the algorithm to eliminate the drift phenomenon. Figure 10 depicts the modified P&O algorithm in which the modifications are highlighted with light green color in the left corner.

The algorithm now uses the current curve to determine the next forward action, effectively eliminating drift. Figure 11 depicts the point-to-point operation of this technique on the P–V curve [50, 51].

- Incremental Conductance (I&C) Algorithm

The IC technique is founded on the slope of power–voltage, as illustrated in Fig. 12. Figure 13 illustrates the flow chart of the IC MPPT. The calculation of the slope of the P–V features is contingent upon taking positive measures point on the left side of the maximum power point tracker (MPPT). In such a scenario, the recommended course of action is to increase the photovoltaic (PV) voltage to align with the optimal solution. If the slope of the standard curve exhibits negativity, the prescribed course of action involves inferring that the operating point is situated on the right-hand side of the MPP. Consequently, it is recommended that the functioning point be shifted towards the left by decreasing the PV voltage. The optimal operating point occurs at the maximum power point (MPP), where the slope of the P–V curve is zero. At this point, the voltage adjusting algorithm will cease according to the subsequent equation.

$$\frac{\Delta I}{\Delta V} = -\frac{I}{V} \text{ at mppt} \tag{6}$$

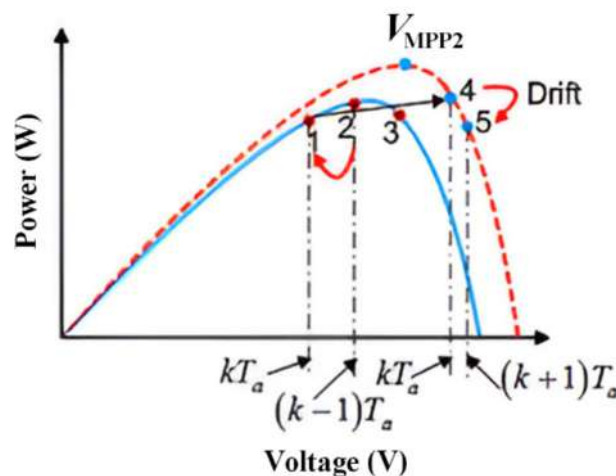

Fig. 9 An example of drift incidence, adapted from [42]

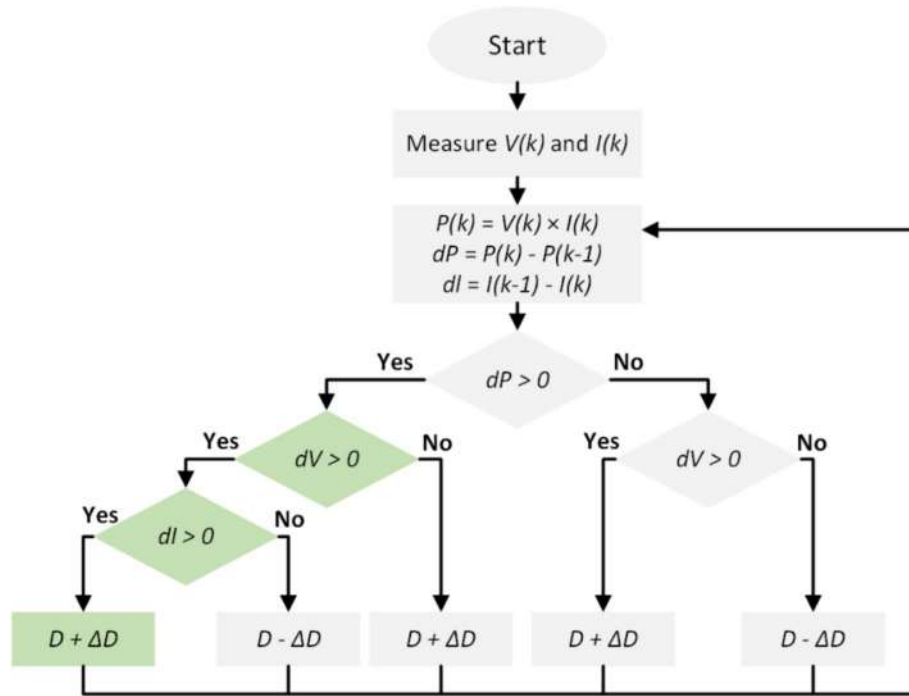

Fig. 10 The modified P&O Algorithm to eliminate the drift problem

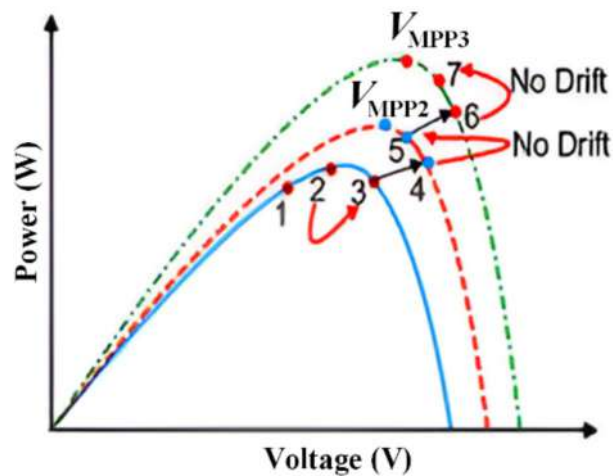

Fig. 11 Algorithm tracking with no drift, adapted from [46]

$$\frac{\Delta I}{\Delta V} > -\frac{I}{V}, \text{ left of mppt} \tag{7}$$

$$\frac{\Delta I}{\Delta V} < -\frac{I}{V}, \text{ right of mppt} \tag{8}$$

3.4 Inverter

The DC/DC boost converter’s output voltage is supplied through an inverter to connect to the 132 kV transmission line. The voltage is converted to three-phase levels. To provide the required three-phase AC source, the inverter circuit needs six square wave signals to drive the transistors, three of which are complements of the other three.

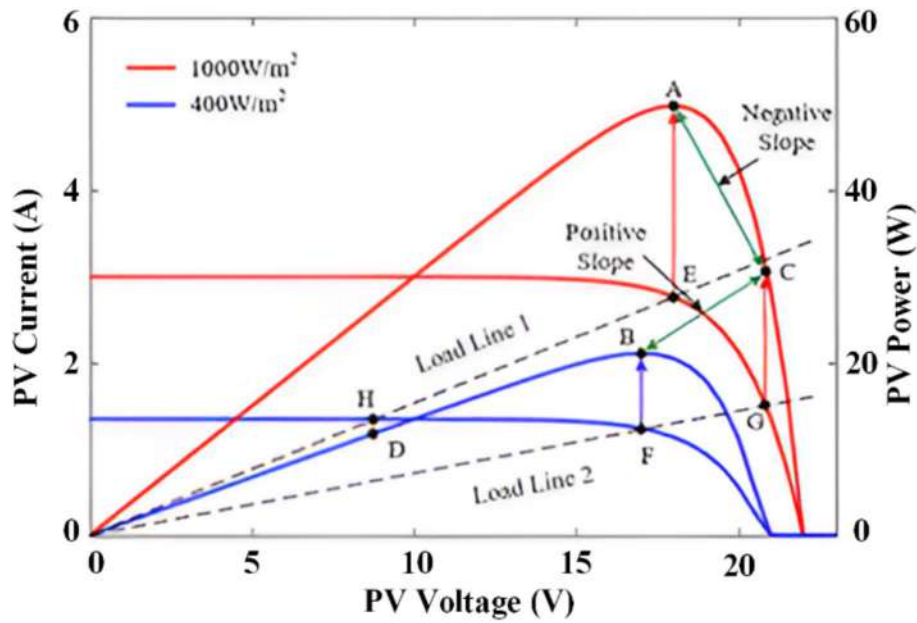

Fig. 12 I&C P-V/I-V curve

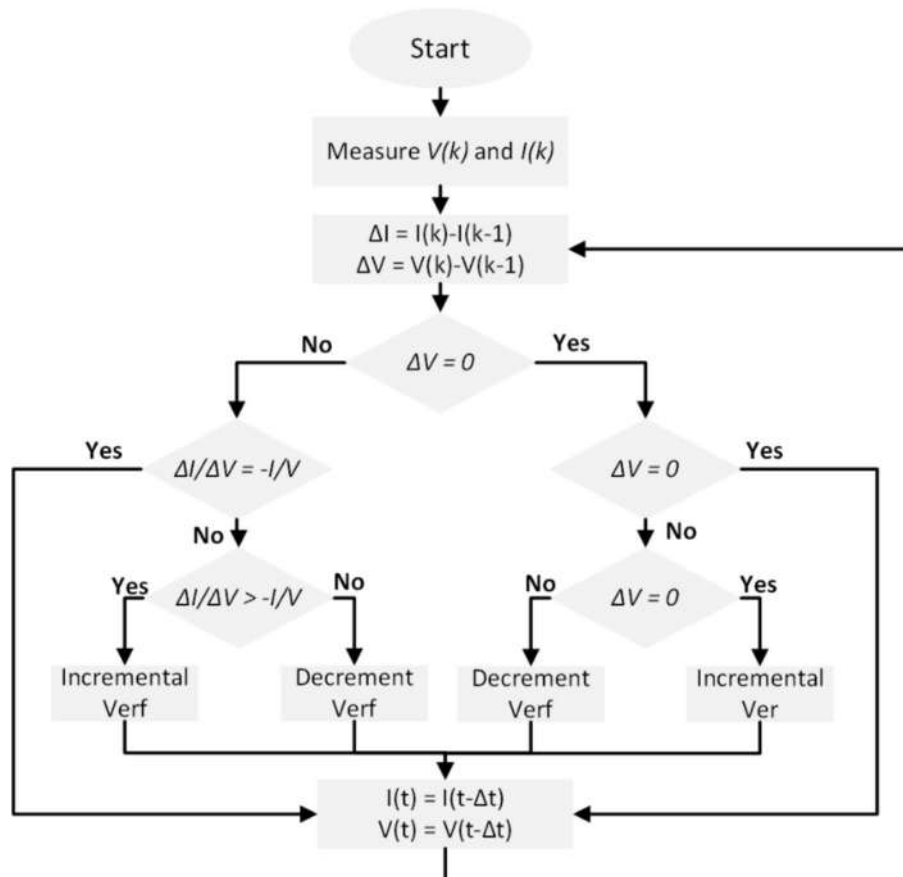

Fig. 13 I&C algorithm

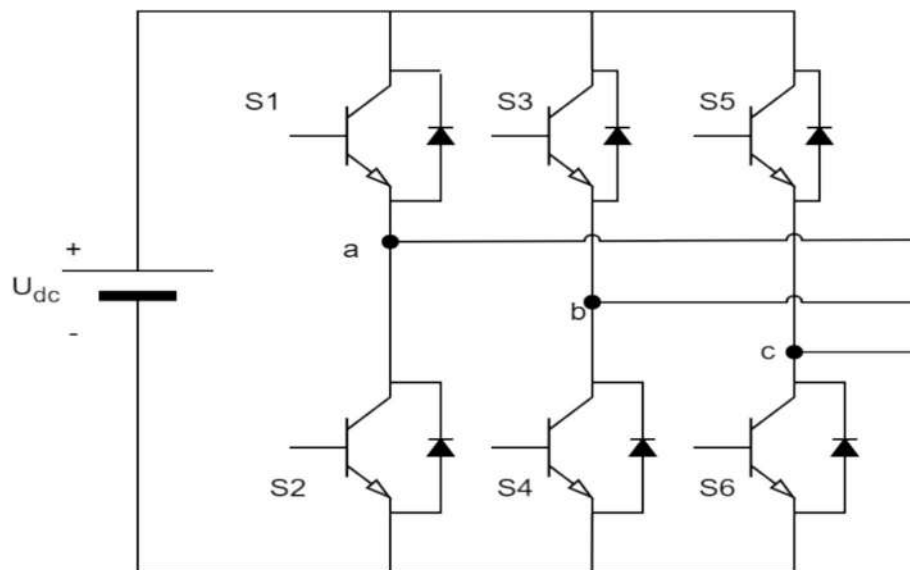

Fig. 14 Power inverter circuit

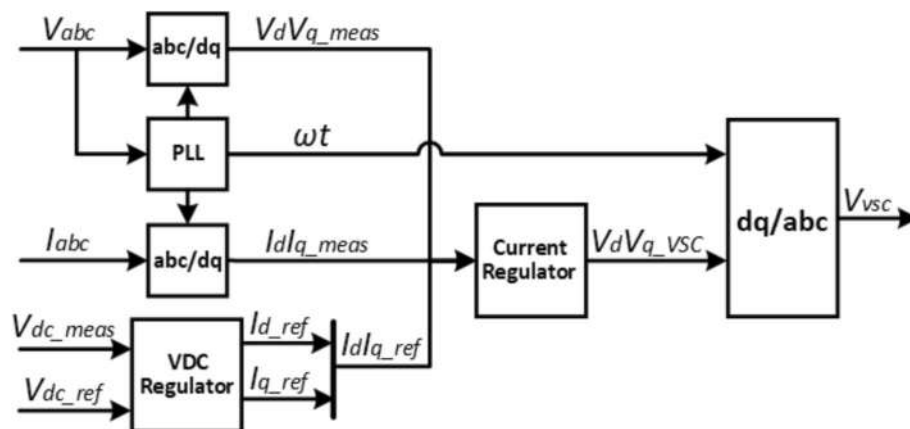

Fig. 15 Block diagram of voltage source converter

Figure 14 shows the schematic of the inverter's basic circuitry. The circuit's three lines (a, b, and c) are for three-phase AC current, and switches (S1 through S6) must be arranged to produce a three-phase sine waveform at a predetermined frequency. Note the series connection between transistors S1 and S2; both cannot be "on" at the same time to avoid a short circuit, so switch S4 must be the complement of S1.

The duty cycle was initially calculated using the standard boost converter equation $V_{out} = V_{in}/(1 - D)$, yielding a value of approximately 45.5% to achieve a 500 V output from a nominal 273 V PV input. This duty cycle was then dynamically adjusted through the MPPT algorithm to maintain optimal operation.

3.5 Voltage source converter (VSC)

The VSC controller is used to generate six square waves for transistor derivation. Three-phase alternating current and voltage from the 132 kV bus are used as inputs to the controller, together with the direct current (DC) voltage from the Boost converter's outcome. Figure 15 shows a high-level view of the VSC controller's block diagram.

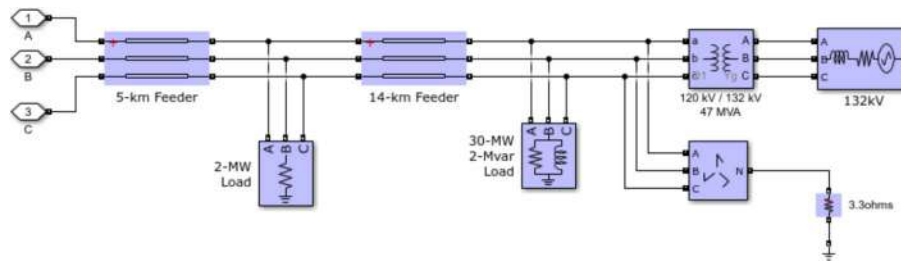

Fig. 16 132 kV transmission line

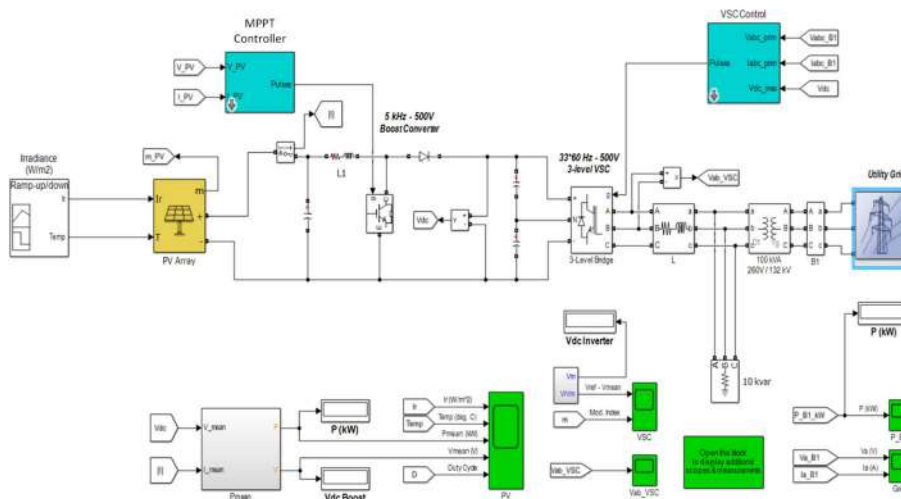

Fig. 17 Simulink model of the developed model

A six-switch three-phase bridge was employed to interface with the 132 kV transmission grid, using complementary PWM signals generated by the Voltage Source Converter (VSC) controller. The inverter was designed to ensure phase synchronization, reduce harmonics, and allow stable grid integration under varying environmental inputs.

3.6 132 kV grid

A triangle signal is required to produce three square waves that can be complemented to generate a square wave. Thus, A 132 kV grid connection has been established, and AC voltages and currents used to generate the triggering signals to make the inverter voltages compatible. The 132 kV is a three-phase power plant, transmission lines, and a minimal number of connected loads. The block diagram of the 132 kV transmission system is shown in Fig. 16.

4 Results and discussion

To analyze the performance of the proposed grid-connected photovoltaic system under dynamic environmental conditions, a comprehensive Simulink model was developed, as illustrated in Fig. 17. The model integrates a PV array, MPPT controller, DC–DC boost converter, three-level inverter, and a 132 kV utility grid interface. Each component was configured to replicate real-world behavior under varying irradiance and temperature levels. The PV system model is developed to obtain maximum power point by testing P&O and I&C method for Iraq conditions by using adjustable variable values of

temperature (0–50 °C) and irradiance reached 1000 W/m² for optimal usage. The Simulink model ran for three seconds. These environmental inputs were connected to the PV module block to dynamically update performance in real-time. This configuration enabled analysis of MPPT algorithm behavior under transient and harsh environmental changes. The sampling time was set to 1 μs to ensure accurate tracking of dynamic changes. The control loop frequency for the MPPT controller and PWM generation was configured at 5 kHz, aligning with the switching frequency of the boost converter. Key assumptions include ideal sensor response, negligible cable losses, and perfect grid synchronization. These assumptions were made to isolate the performance impact of the MPPT algorithms and converter behavior under changing environmental conditions.

The temperature and irradiance values were changed throughout the simulation, as shown in Fig. 18, to investigate their effect on the PV system.

Table 2 summarizes the key components of the Simulink model along with their respective simulation parameters and configurations, which were selected based on standard engineering practices and the operational requirements of grid-connected PV systems in high-temperature regions.

Figures 19 and 20 show the relation between the current and the voltage (I–V curve), and between the power and the voltage (P–V curve), respectively. The findings indicated that the system operated at maximum power for most of the time. Moreover, the panel was very sensitive to the change in several levels of temperature and irradiance as it is losing the curve harmonics and influenced the curve distortion for the voltage between (160–275) V for the P&O method. This distortion affects the maximum output power and reduces system stability. For the same reason, this range of voltage influenced the current distortion as in Fig. 20.

The distortions are primarily caused by switching transients in the power electronic components, particularly the inverter and boost converter. These distortions are more pronounced under rapid irradiance and temperature changes, where the MPPT algorithm reacts dynamically to adjust the duty cycle. The P&O algorithm, due to its

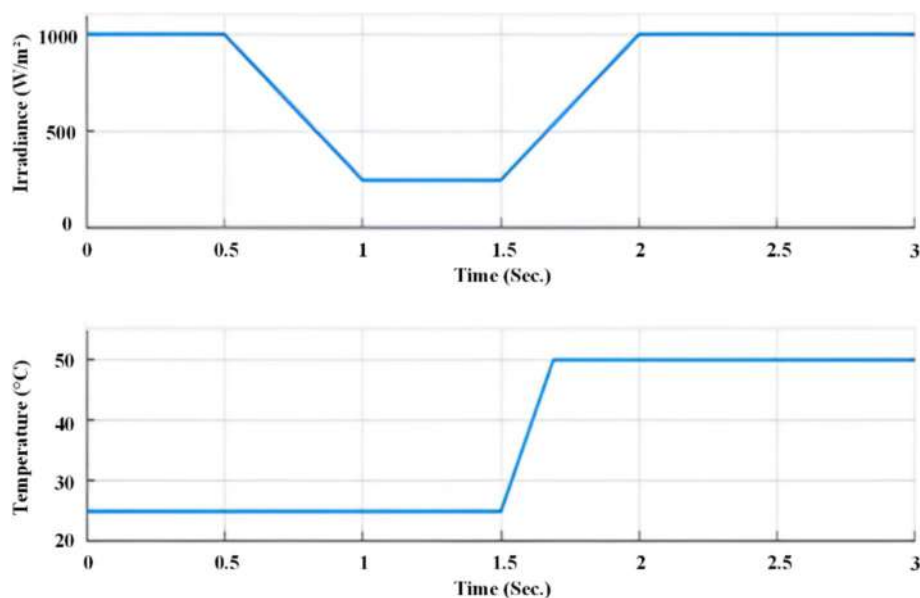

Fig. 18 Temperature and irradiance values throughout the simulation

Table 2 Simulink components and simulation parameters

Component	Description	Simulation parameter/ Value
PV array	Converts solar radiation and temperature into DC electricity	SunPower SPR-305E-WHT-D (5S x 66P)
Irradiance & temperature source	Supplies environmental inputs: irradiance (0–1000 W/m ²) and temperature (0–50 °C)	0–1000 W/m ² , 0–50 °C
MPPT controller	Implements P&O and I&C algorithms for MPPT control	Duty cycle based on voltage and current slopes
Boost converter	Boosts PV voltage to a steady 500 V DC level	500 V output at 5 kHz switching
Inductor (L1)	Smooths current ripple from switching; value: 5 mH	5 mH
Capacitor (C)	Filters DC voltage output; value: 24 mF	24 mF
PWM generator	Generates 5 kHz square wave pulses for the boost converter switch	5 kHz
3-level inverter	Converts DC to 3-phase AC, 33×60 Hz, 500 V output	33×60 Hz, 500 V AC
Grid transformer	Steps up voltage from 500 V to 132 kV for grid compatibility; 100 kVA	260 V/132 kV step-up, 100 kVA
Utility grid	Connects simulation to transmission system (132 kV bus)	132 kV, 3-phase
Load	Represents connected 3-phase load	10 kvar

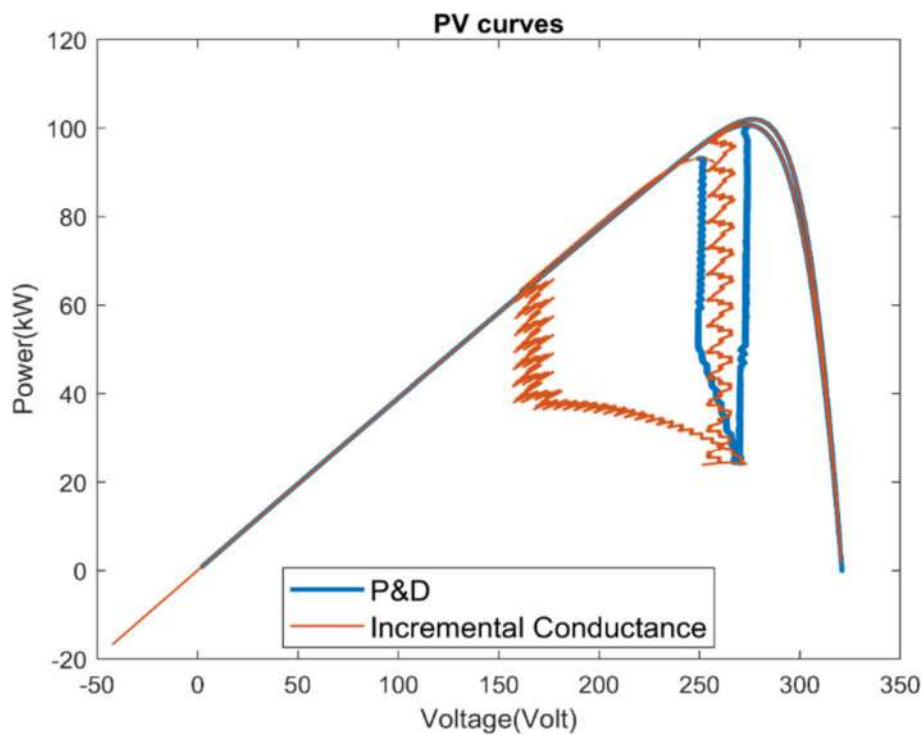

Fig. 19 The relation between the power and the voltage (P–V curve) of the developed PV system

continuous perturbation behavior, introduces small oscillations that lead to higher ripple and harmonic distortion. In contrast, the I&C algorithm stabilizes more quickly, reducing these distortions. The resulting distortions may affect load power quality and increase stress on grid-connected components, thus emphasizing the importance of MPPT algorithm stability.

The results show that the I&C method achieved a power tracking efficiency of 98.7%, whereas P&O recorded 95.2%, indicating improved accuracy in locating and maintaining

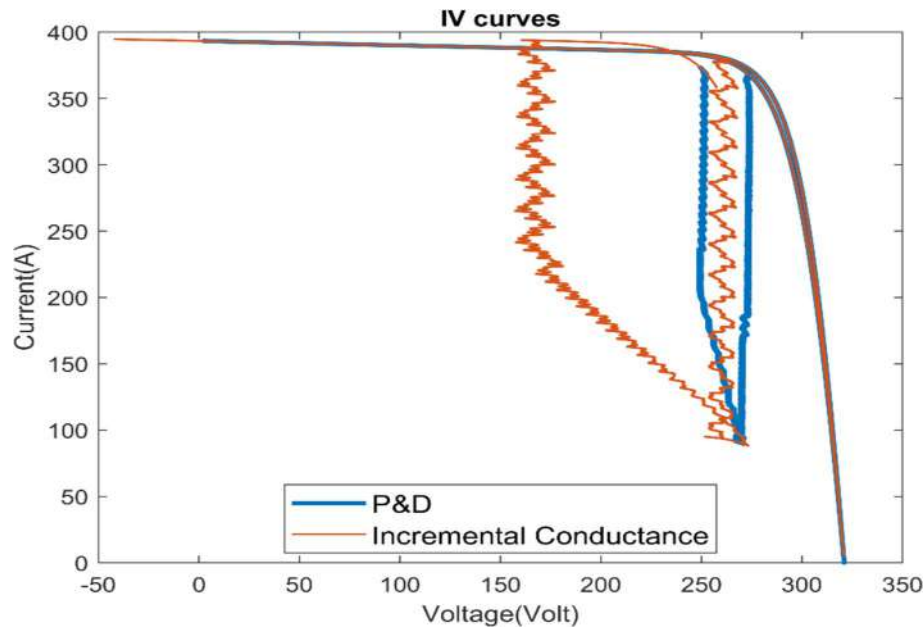

Fig. 20 The relation between the current and the voltage (I–V curve) of the developed PV system

Table 3 MPPT algorithm statistical comparison

Metric	P&O algorithm	I&C algorithm
MPPT tracking efficiency (%)	95.2	98.7
Settling time (s)	0.8	0.45
Convergence time (s)	0.15 s	0.4 s
Power ripple (W)	~1.2 kW	~3.8 kW
Standard deviation of power output (W)	7.2	3.1
Response to irradiance transients	Moderate oscillation	Fast, smooth response
Response to temperature transients	Slight delay	Stable and adaptive

operation at the Maximum Power Point (MPP). The rationale behind this phenomenon is the sensitivity towards abrupt alterations in the level of irradiance. Furthermore, the settling time for I&C was measured at 0.45 s, outperforming the P&O algorithm, which settled in 0.8 s. With respect to ripple, the output power fluctuation observed with I&C was limited to ± 1.2 kW, while P&O exhibited a higher ripple of approximately ± 3.6 kW. These metrics clearly highlight the superior stability and faster dynamic response of the I&C approach over the classical P&O method.

The lower standard deviation in power output for I&C further reflects its enhanced stability and robustness, making it more suitable for applications requiring reliable power quality. These findings confirm that while both algorithms are well-established, the I&C method provides a more stable and efficient solution, particularly under non-ideal environmental scenarios like those modeled for Iraqi conditions. Table 3 summarizes MPPT Algorithm Statistical Comparison.

The power produced from the PV to the grid and the output voltage of the boost converter are shown in Fig. 21. The duty cycle remains constant despite changes in temperature and irradiance, resulting in slight movement over the MPP, which is a disadvantage of P&O method. The system also displays the utility grid's currents, voltages, and powers, as well as synchronization with the transmission network. It is noteworthy

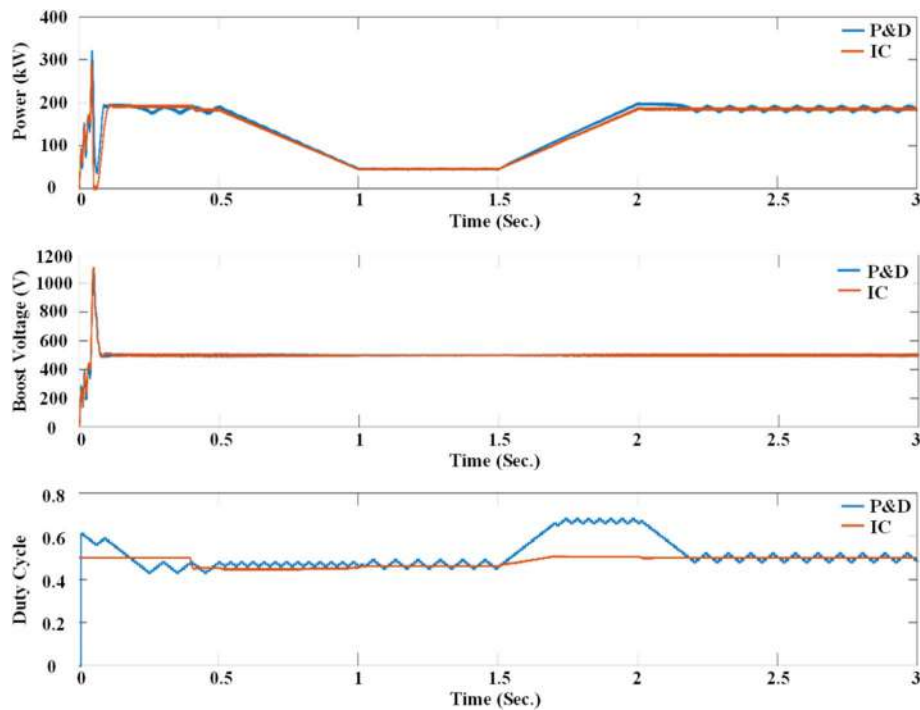

Fig. 21 PV power, converter voltage, and duty cycle response under P&O and I&C algorithms

that the power consumption from both the PV module and boost converter exhibits a near equivalence. It is observed that the I&C algorithm results in a more consistent and reliable power output from the photovoltaic module compared to the P&O algorithm. Additionally, in the context of the P&O algorithm, it is observed that the duty cycle plot exhibits repetitive behavior once it reaches a stable state following alterations in irradiance or temperature. The data indicates that the system is experiencing slight movement along the MPP.

The dynamic behavior of the P&O and I&C algorithms was evaluated under varying irradiance and temperature profiles. The simulation results showed that the I&C algorithm exhibited faster convergence to the Maximum Power Point (MPP) with minimal steady-state oscillations. Specifically, the convergence time of I&C was observed to be approximately 0.15 s, whereas the P&O algorithm required around 0.4 s to settle around the MPP after perturbation.

In terms of stability, I&C maintained more consistent voltage and current profiles, whereas the P&O method demonstrated larger oscillatory behavior near the MPP, especially under abrupt irradiance transitions. This is attributed to P&O's fixed-step perturbation nature, which can overshoot the MPP or cause divergence under rapid environmental changes. These observations underscore the superior dynamic performance and faster adaptation of the I&C method, making it more suitable for environments with frequent fluctuations in solar conditions, such as those encountered in Iraq.

Figures 22 and 23 show the network current and voltage at three phases under ramp variations of radiation and temperature. The analysis revealed that the transmission current follows the maximum current, and the voltage remains steady to maintain transmission line synchronization.

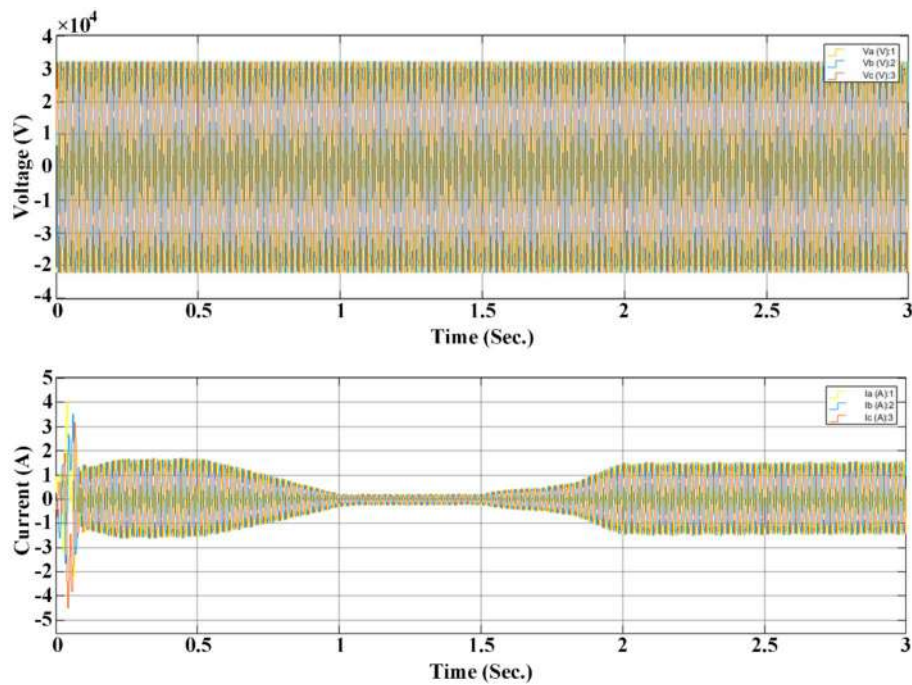

Fig. 22 Voltage and current for 132 kV Bus

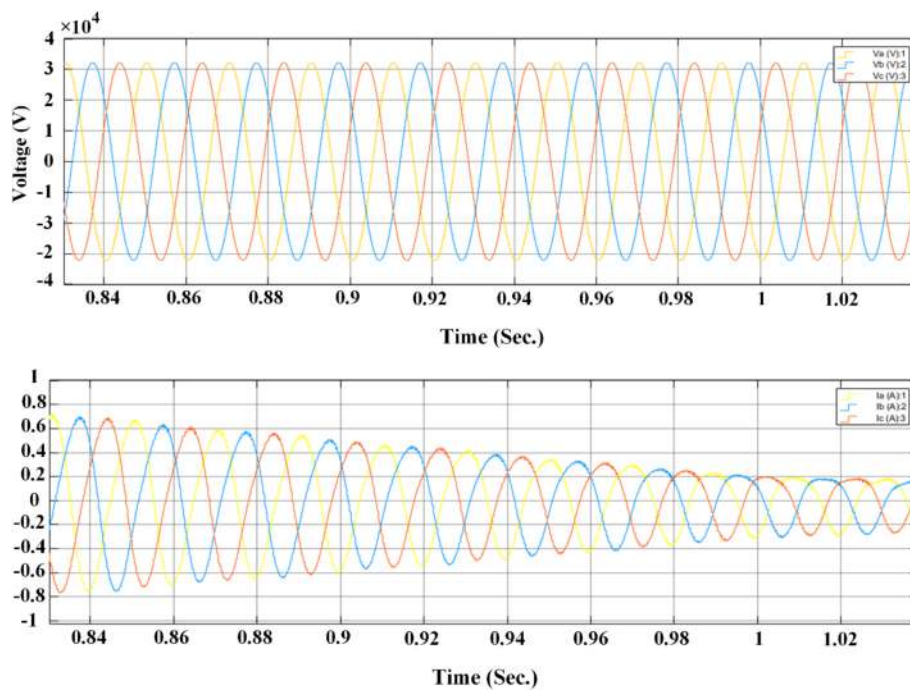

Fig. 23 3-phase voltage and currents (Zoom view)

It can be observed from Fig. 22 that the voltage is stable, while the current decreases at time from 1 to 2, due to the sudden change in radiation and heat. Moreover, the analysis revealed accurate current and voltage values displayed in the zoom view of Fig. 23 below.

Figure 24 depicts the voltage and current of the inverter. The instability in voltage and current is caused by the ripple voltage of the boost converter. Boost converters are not

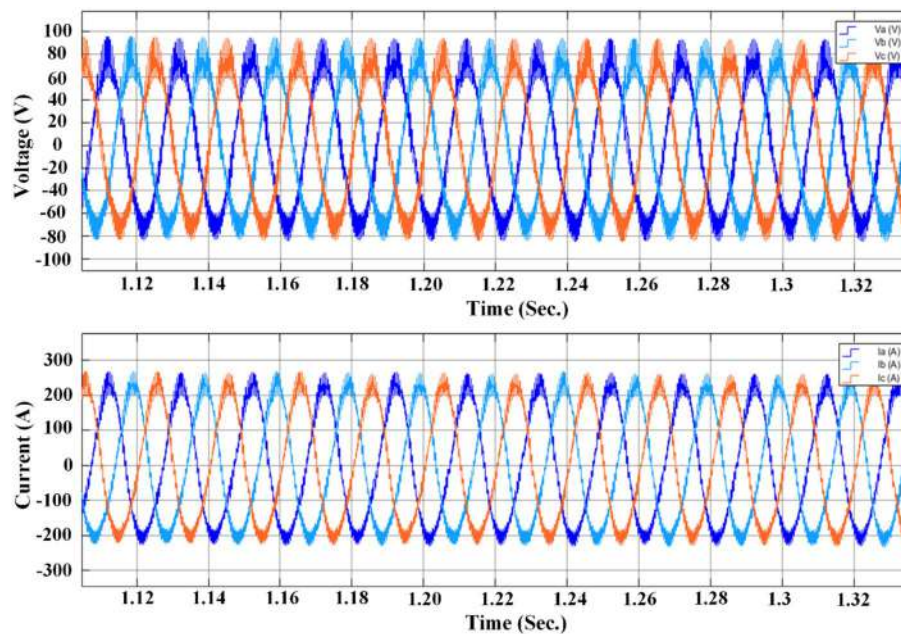

Fig. 24 Voltage and current of the inverter

ideal amplifiers, and they introduce voltage distortion with a defined range of acceptable voltages. For example, for a 500 V output, the voltage must be between 495 and 505 V with a ripple voltage of ± 5 V. Improving the boost converter's architecture can reduce the ripple voltage, but it may not be lower than 0.4. The ripple voltage is responsible for the imperfection in the 3-phase output voltage and current of the inverter.

This ripple directly affects the inverter's modulation stability, leading to minor deviations in the output voltage waveform. In addition to tracking performance, the output waveform quality of the inverter was also evaluated. Total Harmonic Distortion (THD) analysis was performed on the inverter's AC output under steady-state conditions. The THD value was found to be below 3.1%, which complies with IEEE-519 standards for grid-connected systems. This indicates that the output waveform is of high quality and suitable for grid integration. The low THD further confirms the stability and effectiveness of the implemented MPPT methods, especially under varying irradiance and temperature conditions. These findings highlight the significance of minimizing ripple at the DC link to ensure high-quality AC output, especially in grid-connected systems.

The ripple effect observed in the boost converter output significantly impacts the system's voltage stability and overall power quality. As shown in Fig. 24, the inverter voltage exhibits periodic oscillations around the desired output level due to inherent characteristics of the boost converter. The ripple voltage was measured to be approximately ± 5 V, which corresponds to a ripple ratio of 1% for a nominal 500 V DC link. Although this is within the acceptable design tolerance, it introduces minor fluctuations in the inverter's AC output, which in turn can slightly affect synchronization and power delivery to the grid. These ripple-induced variations were more pronounced in the P&O algorithm due to its higher duty cycle variability, while the I&C method resulted in smoother transitions and more stable current and voltage profiles. Therefore, improving the converter filtering stage or adopting more robust MPPT algorithms can help further mitigate these effects and enhance system reliability.

Table 4 Comparative analysis of P&O and I&C MPPT algorithms based on computational complexity, implementation cost, scalability, and robustness

Attribute	Perturb & Observe (P&O)	Incremental Conductance (I&C)
Computational complexity	Low (i.e., simple control logic using arithmetic comparisons) [56]	Moderate (i.e., requires real-time slope estimation (dI/dV)) [54, 57]
Implementation cost	Lower (i.e., runs on basic microcontrollers or analog circuitry) [58]	Slightly higher (i.e., needs more memory and precision) [54, 57]
Scalability	High (i.e., well-suited for modular, small- to medium-scale systems)	Moderate (i.e., more applicable in systems with adequate computing power)
Hardware requirements	Minimal (i.e., 8-bit MCU sufficient) [58]	Moderate (i.e., 16/32-bit MCU or DSP preferred) [54, 56]
Robustness to noise	Less robust (i.e., sensitive to oscillations near MPP) [55, 59]	More robust (i.e., better stability under rapidly changing conditions) [54, 57]

To assess the relative performance of classical MPPT techniques implemented in this study (P&O and I&C), we compare our results with those from recent literature that proposed enhanced variants of hill-climbing and hybrid MPPT strategies. Sharma et al. (2016) introduced a modified hill-climbing algorithm that achieved a power tracking efficiency of 98.1% with minimal steady-state oscillations under rapidly changing irradiance, yet required longer convergence time during large irradiance shifts [46]. Lu et al. (2017) developed a dual-tracking MPPT approach combining voltage and power feedback, demonstrating faster dynamic response but with slightly increased steady-state ripple [52]. Jatily et al. (2021) proposed a reference-based MPPT technique utilizing adaptive reference values for current and voltage, showing superior convergence speed (under 50 ms) and reduced ripple, but with increased computational complexity and hardware overhead [53].

In comparison, our implementation of I&C under Iraq-specific environmental profiles achieved a tracking efficiency of 98.7%, with settling time under 0.45 s and limited ripple observed around ± 5 W, which is competitive with recent techniques while maintaining algorithmic simplicity and ease of integration with the grid-connected 132 kV infrastructure. The inclusion of a full transmission-level integration and evaluation under real-world temperature and irradiance variation further distinguishes our work in terms of practical deployment readiness and environmental realism.

Beyond tracking accuracy and dynamic performance, MPPT algorithms must also be evaluated based on their suitability for real-world deployment. Factors such as computational complexity, hardware cost, and scalability can significantly influence algorithm selection, especially in large-scale or resource-constrained PV applications [54, 55]. Table 4 summarizes the practical differences between P&O and I&C, incorporating insights from recent studies.

Although I&C outperforms P&O in accuracy and responsiveness, it introduces greater computational demand and requires a higher-performance controller. These trade-offs must be weighed according to the scale, cost constraints, and control requirements of the target PV system.

5 Conclusion

This study presented a simulation-based evaluation of MPPT strategies within a grid-connected photovoltaic system under challenging environmental conditions representative of Iraq. Beyond comparing P&O and I&C algorithms, the research offers a utility-scale modeling approach that reflects real-world integration scenarios, such as

connection to a 132 kV transmission grid. While the findings demonstrate the advantages of classical algorithms—particularly the superior responsiveness and stability of I&C—this work also highlights the practical constraints and opportunities in PV deployment for high-temperature regions. A key limitation remains the absence of experimental validation, which is essential for confirming the real-world applicability of the proposed system. Future work will involve hardware prototyping and testing, alongside exploring intelligent MPPT techniques such as fuzzy logic, reinforcement learning, and neural networks. These advanced methods have the potential to address the limitations of rule-based algorithms, offering faster adaptation to environmental transients and enhanced system resilience. Ultimately, this research contributes to the broader goal of optimizing solar energy extraction in regions with extreme climate conditions and complex grid requirements.

Author contributions

A.E. and A.A.A. developed the initial concept, designed the study methodology, and performed the simulations. A.E. and M.B. contributed to the modeling of the photovoltaic system and the analysis of the MPPT algorithms. M.B. and A.A.A. provided technical insights related to system optimization and MATLAB/Simulink modeling. Z.B. prepared the figures, tables, and contributed to the comparative analysis of results. S.S. supervised the overall research activity, verified the simulation results, and reviewed and edited the manuscript. All authors reviewed, discussed, and approved the final version of the manuscript.

Funding

This research received no external funding.

Data availability

The data that support the findings of this study are available from the corresponding author upon reasonable request.

Declarations

Ethics approval and consent to participate

Not applicable.

Consent to publish

Not applicable.

Competing Interests

The authors declare no competing interests.

Received: 26 April 2025 / Accepted: 7 August 2025

Published online: 23 August 2025

References

1. Dawood H, Altai S, Abed FT, Lazim MH. Analysis of the problems of electricity in Iraq and recommendations of methods of overcoming them. *Period Eng Natural Sci.* 2022;10(1):607–14.
2. M. of Electric, Annual report; 2022.
3. Derbeli M, Napole C, Barambones O, Sanchez J, Calvo I, Fernández-Bustamante P. Maximum power point tracking techniques for photovoltaic panel: a review and experimental applications. *Energies.* 2021;14(22):7806.
4. Abdelwahab SAM, Hamada AM, Abdellatif WSE. Comparative analysis of the modified perturb and observe with different MPPT techniques for PV grid connected systems. *Int J Renew Energy Res.* 2020;10(1):55–164.
5. Al-Majidi SD, Abbod MF, Al-Raweshidy HS. A novel maximum power point tracking technique based on fuzzy logic for photovoltaic systems. *Int J Hydrog Energy.* 2018;43(31):14158–71.
6. Kareem MM, Lafta SAS, Hashim HF, Al-Azzawi RK, Ali AH. Analyzing the BER and optical fiber length performances in OFDM RoF links. *Indones J Electr Eng Comput Sci.* 2021;23(3):1501–9.
7. Abdelaziz AY, Almoataz Y. *Modern maximum power point tracking techniques for photovoltaic energy systems.* Springer; 2020.
8. Ali AH, Hamad HS, Abdulrazzaq AA. An adaptable different-levels cascaded h-bridge inverter analysis for PV grid-connected systems. *Int J Pow Elec Dri Syst.* 2019;10(2):831–41.
9. Abbas AM, et al. The implementation of multi-task geophysical survey to locate Cleopatra tomb at tap-Osiris Magna, Borg El-Arab, Alexandria, Egypt 'phase II'. *NRIAG J Astron Geophys.* 2012;1(1):1–11.
10. Mao M, Cui L, Zhang Q, Guo K, Zhou L, Huang H. Classification and summarization of solar photovoltaic MPPT techniques: a review based on traditional and intelligent control strategies. *Energy Rep.* 2020;6:1312–27.
11. Zainuddin NF, Mohammed MN, Al-Zubaidi S, Khogali SI. Design and development of smart self-cleaning solar panel system. In 2019 IEEE international conference on automatic control and intelligent systems (I2CACIS); 2019. pp. 40–43.

12. Hashim N, Mohammed MN, Al Selvarajan R, Al-Zubaidi S, Mohammed S. Study on solar panel cleaning robot. In 2019 IEEE international conference on automatic control and intelligent systems (I2CACIS); 2019. pp. 56–61. <https://doi.org/10.1109/I2CACIS.2019.8825028>.
13. Sarvi M, Azadian A. A comprehensive review and classified comparison of MPPT algorithms in PV systems. *Energy Syst.* 2022;13(2):281–320.
14. Kathe ML, Makokha AB, Zachary SO, Adaramola MS. A comprehensive review of maximum power point tracking (MPPT) techniques used in solar PV systems. *Energies.* 2023;16(5):2206.
15. Hasan MK, Habib AA, Islam S, Balfaqih M, Alfawaz KM, Singh D. Smart grid communication networks for electric vehicles empowering distributed energy generation: constraints, challenges, and recommendations. *Energies.* 2023;16(3):1140.
16. Balfaqih M, Alharbi SA. Associated information and communication technologies challenges of smart city development. *Sustainability.* 2022;14(23):16240.
17. Devarakonda AK, Karuppiah N, Selvaraj T, Balachandran PK, Shanmugasundaram R, Senjyu T. A comparative analysis of maximum power point techniques for solar photovoltaic systems. *Energies.* 2022;15(22):8776.
18. Basha CHH, Rani C. Different conventional and soft computing MPPT techniques for solar PV systems with high step-up boost converters: a comprehensive analysis. *Energies.* 2020;13(2):371.
19. Shadlu MS. Comparison of maximum power point tracking (MPPT) algorithms to control DC–DC converters in photovoltaic systems. *Recent Adv Electr Electron Eng.* 2019;12(4):355–67.
20. Mnati MJ, Chisab RF, Al-Rawi AM, Ali AH, Van den Bossche A. An open-source non-contact thermometer using low-cost electronic components. *HardwareX.* 2021;9:e00183.
21. Muslim HN. Challenges and barriers in Iraq for solar PV generation: a review. *Int J Energy Environ.* 2019;10(3):97–102.
22. Bamisile O, Olubiyo F, Dagbasi M, Adun H, Wole-Osho I. Economic analysis and performance of PV plants: an application in Kurdistan Region of Iraq. *Int J Renew Energy Dev.* 2019. <https://doi.org/10.14710/ijred.8.3.293-301>.
23. Ali OM, Alomar OR. Technical and economic feasibility analysis of a PV grid-connected system installed on a university campus in Iraq. *Environ Sci Pollut Res.* 2023;30(6):15145–57.
24. Kazem AA, Chaichan MT, Kazem HA. Dust effect on photovoltaic utilization in Iraq. *Renew Sustain Energy Rev.* 2014;37:734–49.
25. Hussein BN, Essa IA, Hussein DJ. Introducing a PV design program compatible with Iraq conditions. *Energy Proc.* 2013;36:852–61.
26. Abada HH, Al-Shamani AN, Faisal MD. A grid connected PV system for a rural resident in Al-Najaf, Iraq. In: AIP conference proceedings. AIP Publishing LLC; 2020 (Vol. 2290, No. 1, p. 050056).
27. Abed FT, Altai HDS, Hazim HT, ALRikabi HTS. Enhancement of the efficiency of solar energy cells by selecting suitable places based on the simulation of PV system. *Period Eng Natural Sci (PEN).* 2022;10(2):80–8.
28. Al-akaysee AS, Kuznetsov ON, Sultan HM. Optimization and operation of stand-alone hybrid PV/Biomass/Hydroelectric pumped storage energy system in Iraq. In: 2021 IEEE conference of Russian young researchers in electrical and electronic engineering (EIConRus). IEEE; 2021. pp. 1365–1370.
29. Mahdi AJ. Design and performance analysis of an on-grid photovoltaic power system under Iraqi solar circumstances. *J Eng Sustain Dev.* 2017;21(4):46–57.
30. Mahmood AL, Shakir AM, Numan BA. Design and performance analysis of stand-alone PV system at Al-Nahrain University, Baghdad, Iraq. *Int J Power Electron Drive Syst.* 2020;11(2):921.
31. Bendib B, Krim F, Belmili H, Almi MF, Boulouma S. Advanced fuzzy MPPT controller for a stand-alone PV system. *Energy Proc.* 2014;50:383–92.
32. Cubas J, Pindado S, De Manuel C. Explicit expressions for solar panel equivalent circuit parameters based on analytical formulation and the lambert W-function. *Energies.* 2014;7(7):4098–115. <https://doi.org/10.3390/en7074098>.
33. Irwanto M, et al. Photovoltaic powered DC–DC boost converter based on PID controller for battery charging system. *J Phys Conf Ser.* 2020. <https://doi.org/10.1088/1742-6596/1432/1/012055>.
34. Endiz MS. Comparative analysis of P&O and IC MPPT techniques under different atmospheric conditions. *El-Cezeri.* 2023;10(1):27–35.
35. Aifan G, Alsulami A, Alhussainy AA, Allehyani A, Alturki YA, Alghamdi SM, Alruwaili M, Alharthi YZ. A comparison of several maximum power point tracking algorithms for a photovoltaic power system. *Front Energy Res.* 2024;27(12):1413252.
36. Thanh TH, Al-Fahham M, Zhang L. Enhancing solar power efficiency: a comparison of MPPT techniques for grid-tied PV systems. *Front Energy Res.* 2025;12:1–12.
37. Siddique MAB, Zhao D, Rehman AU. Emerging maximum power point control algorithms for PV system: review, challenges and future trends. In: *Electrical engineering; 2025*, pp. 1–33.
38. Siddique MAB, Zhao D, Ouahada K, Rehman AU, Hamam H. Performance validation of global MPPT for efficient power extraction through PV system under complex partial shading effects. *Sci Rep.* 2025;15(1):1–24.
39. Siddique MAB, Zhao D, Rehman AU, Shandilya G, Bharany S. Implementation and performance analysis of optimization based GMPP tracking algorithms for a PV array under various shading effects. In: 2024 global conference on communications and information technologies (GCCIT). IEEE; 2024. pp. 1–6.
40. Siddique MAB, Zhao D, Jamil H. Forecasting optimal power point of photovoltaic system using reference current based model predictive control strategy under varying climate conditions. *Int J Control Autom Syst.* 2024;22(10):3117–32.
41. Siddique MAB, Zhao D, Xing Y. Validating the optimum response of MPPT under dynamic irradiance and load variations effect on the output power of the PV system. In: 2024 43rd Chinese control conference (CCC). IEEE; 2024. pp. 6281–6286.
42. Belghiti H, Kandoussi K, Harrison A, Moustaine FZ, Otmani RE, Sadek EM, Bajaj M, Dost Mohammadi SA. A novel adaptive FOCV algorithm with robust IMRAC control for sustainable and high-efficiency MPPT in standalone PV systems: experimental validation and performance assessment. *Sci Rep.* 2024;14(1):31962.
43. Alombah NH, Harrison A, Mbasso WF, Belghiti H, Fotsin HB, Jangir P, Al-Gahtani SF, Elbarbary ZMS. Multiple-to-single maximum power point tracking for empowering conventional MPPT algorithms under partial shading conditions. *Sci Rep.* 2025;15(1):14540.
44. Belghiti H, Kandoussi K, Harrison A, Moustaine FZ, Sadek EM. Simplified control algorithm for stable and efficient stand-alone PV systems: an assessment based on real climatic conditions. *Comput Electr Eng.* 2024;120:109695.
45. Jately V, Azzopardi B, Joshi J, Sharma A, Arora S. Experimental Analysis of hill-climbing MPPT algorithms under low irradiance levels. *Renew Sustain Energy Rev.* 2021;150:111467.

46. Jatly V, Arora S. Performance investigation of Hill-Climbing MPPT techniques for PV systems under rapidly changing environment. In: Intelligent communication, control and devices: proceedings of ICICCD 2017. Singapore: Springer. pp. 1145–1157
47. . Michal V. Dynamic duty-cycle limitation of the boost DC/DC converter allowing maximal output power operations. In: 2016 international conference on applied electronics (AE); 2016. IEEE. pp. 177–182
48. Killi M, Samanta S. Modified perturb and observe MPPT algorithm for drift avoidance in photovoltaic systems. *IEEE Trans Ind Electron*. 2015;62(9):5549–59. <https://doi.org/10.1109/TIE.2015.2407854>.
49. Thomas D, Rajkumar G. An energy-stored quasi-z-source inverter using SVPWM technique; 2016
50. Sun Y, et al. The impact of PLL dynamics on the low inertia power grid: a case study of Bonaire island power system. *Energies*. 2019;12(7):1–16. <https://doi.org/10.3390/en12071259>.
51. Jatly V, Arora S. An efficient hill-climbing technique for peak power tracking of photovoltaic systems. In: 2016 IEEE 7th power India international conference (PIICON); 2016. IEEE. pp. 1–5
52. Jatly V, Arora S. Development of a dual-tracking technique for extracting maximum power from PV systems under rapidly changing environmental conditions. *Energy*. 2017;133:557–71.
53. Jatly V, Bhattacharya S, Azzopardi B, Montgareuil A, Joshi J, Arora S. Voltage and current reference based MPPT under rapidly changing irradiance and load resistance. *IEEE Trans Energy Convers*. 2021;36(3):2297–309.
54. Esram T, Chapman PL. Comparison of photovoltaic array maximum power point tracking techniques. *IEEE Trans Energy Convers*. 2007;22(2):439–49.
55. Hohm DP, Ropp ME. Comparative study of maximum power point tracking algorithms. *Prog Photovolt Res Appl*. 2003;11(1):47–62.
56. Femia N, Petrone G, Spagnuolo G, Vitelli M. Optimization of perturb and observe maximum power point tracking method. *IEEE Trans Power Electron*. 2005;20(4):963–73.
57. Subudhi B, Pradhan R. A comparative study on maximum power point tracking techniques for photovoltaic power systems. *IEEE Trans Sustain Energy*. 2012;4(1):89–98.
58. Salas V, Ollas E, Barrado A, Lazaro A. Review of the maximum power point tracking algorithms for stand-alone photovoltaic systems. *Solar Energy Mater Solar Cells*. 2006;90(11):1555–78.
59. Koutroulis E, Kalaizakis K, Voulgaris NC. Development of a microcontroller-based, photovoltaic maximum power point tracking control system. *IEEE Trans Power Electron*. 2002;16(1):46–54.

Publisher's Note

Springer Nature remains neutral with regard to jurisdictional claims in published maps and institutional affiliations.