

# Effat University Repository

## Smart Sprinkler System for Water Conservation

Item Type	Article
Authors	A. Johar, Rana
Publisher	Effat University
Download date	2025-05-12 05:54:05
Link to Item	<a href="http://hdl.handle.net/20.500.14131/227">http://hdl.handle.net/20.500.14131/227</a>

2020

## Smart Sprinkler System for Water Conservation

Rana A. Johar  
*Effat University*, [rajohar@effatuniversity.edu.sa](mailto:rajohar@effatuniversity.edu.sa)

Follow this and additional works at: <https://digitalcommons.aaru.edu.jo/eurj>



Part of the [Urban, Community and Regional Planning Commons](#)

### Recommended Citation

A. Johar, Rana (2020) "Smart Sprinkler System for Water Conservation," *Effat Undergraduate Research Journal*: Vol. 1 : Iss. 1 , Article 9.

Available at: <https://digitalcommons.aaru.edu.jo/eurj/vol1/iss1/9>

This Article is brought to you for free and open access by Arab Journals Platform. It has been accepted for inclusion in Effat Undergraduate Research Journal by an authorized editor. The journal is hosted on [Digital Commons](#), an Elsevier platform. For more information, please contact [rakan@aarj.edu.jo](mailto:rakan@aarj.edu.jo), [marah@aarj.edu.jo](mailto:marah@aarj.edu.jo), [u.murad@aarj.edu.jo](mailto:u.murad@aarj.edu.jo).

# Smart Sprinkler System for Water Conservation

Rana Johar

Electrical & Computer Engineering Department  
College of Engineering, Effat University, Jeddah, Saudi Arabia

---

**Abstract:** One of the main problems facing modern cities is water scarcity. The increasing level of water wastage in the irrigation system is an alarming problem. According to the 2030 vision, a reduction in water wastage is sought. This represents a strong motivation to create a simple device to achieve water efficiency. Home sprinkler water flow systems do not take into consideration the current state of the surroundings, which lead to high wastage of water.

In this research paper, a conceptual smart travelling sprinkler composed of a water pump and a motion motor is proposed. The suggested circuit design includes sensors that are capable of detecting soil conditions, such as moisture level and object proximity. The device power is provided by a solar panel that is connected to the water tank, which incorporates a level indicator. A series of pushbuttons and LCDs can be integrated for control purpose. The desired objective is the reduction of water consumption, and this brings us one-step closer to achieving the 2030 vision.

**Keywords:** 2030 vision, electricity saving, solar energy, sprinkler system, water efficiency.

---

## **I. ACKNOWLEDGMENT**

I would begin first and for all by thanking Allah for giving me the chance to learn by trying and succeed after failing. I would like to extend my gratitude to my advisor Prof.Ahmed Bensenouci for his constant support, guidance and useful critique of this research.

## II. INTRODUCTION

Water is a vital element, which covers 70% of our planet. It is essential for all living organisms to survive. It is needed in industrial units, production units and the agricultural sector. There is only 3% of fresh water for drinking, irrigation etc. The two-thirds of that is in the frozen glaciers, which make it unavailable for use. This results in approximately 1.1 billion people worldwide with no access to water, whilst 2.4 billion suffer a water sanitization problem. This exposes them to different diseases such as typhoid fever and cholera [1]. The Kingdom of Saudi Arabia has a total population of nearly 30 million and an area of 2.25 million square kilometers. Through the past three decades, the Kingdom has witnessed an increasing growth rate in the population. This placed a stress on water consumption in all sectors, the most affected of which were the agricultural, municipal and industrial sectors. Saudi Arabia is geographically positioned in an arid area with paucity of rain and limited groundwater reservoirs, which are rapidly depleting. Considering these conditions, water saving techniques and devices are a necessity [2], [3].

Agriculture is a major consumer of water and wastes much of it through inefficient techniques. At this current consumption rate, water sources will be reduced greatly. By 2025, almost two-thirds of the population of the world and the ecosystem may face water scarcity [1].

Developing methods for conserving water is a rising demand that the Saudi government is aspiring to achieve [4].

1. According to the Ministry of Water, the average water consumption per capita is 300 litres per day. This high level of consumption exceeds the global proportions.
2. Confirming that the agricultural sector consumes about 88 percent of the total water consumption in the Kingdom, Mansour Al-Kredes, a member of the Water, Agriculture and Environment Committee in the Shoura Council, put it thus;

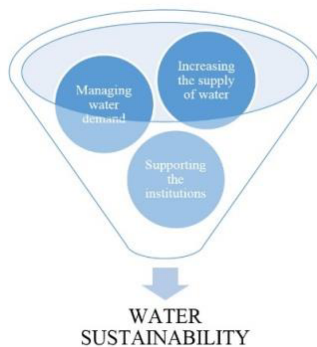

Fig. 1 Water sustainability

*By preserving our environment and natural resources, we fulfill our Islamic, human and moral duties. Preservation is also our responsibility to future generations and essential to the quality of our daily lives. We will also promote the optimal use of our water resources by reducing consumption and utilizing treated and renewable water. (Saudi Vision 2030) [5]*

## III. CURRENT IRRIGATION SYSTEMS

There are different types of irrigation systems to choose from depending on several factors. The natural conditions such as soil type, climate, water quality and availability have an impact on the choice of an irrigation method. The sprinklers are manmade imitation of rainfall. The basic concept for the sprinkler irrigation system is to spray water over the crops in the field. The pipeline technique has two types known as the main and lateral. The main pipe will carry the water from the fixed source then deliver it to the lateral pipeline. The lateral pipeline will spray the water received through the nozzles. Residential sprinklers vary in size depending on the lawn, cost and size of the garden. They are usually attached to a water faucet placed outdoors. An underground sprinkler depends on the hydraulic or electronic technology; it is a heavy-duty system which requires a higher amount of pressurized water [6]. Sprinklers are usually found in residential areas, resorts and golf courses [7].

The retail prices of the fixed sprinkler price range from 24 to 50 riyals. Although it is cheap, it needs a handy man to install it, since it is difficult for the consumer to assemble it. The rotating sprinkler's price is approximately 100 riyals. It is used for fields that need constant irrigation. The rotating head needs constant maintenance to clean the clogged nozzle. In some systems, the rotating head cannot withstand the water

pressure and spins around uncontrollably. With the development of technology, a self-propelled water sprinkler was invented; its price approximately ranged between 257 and 266 riyals. This offers more flexibility than the other methods.

Water sprinklers witnessed an evolution through the years as they developed from stationary to rotating and to portable water sprinkling systems. They started back in 1977 with George Garcia's [8] study leading to an invention. This was a portable irrigation device. The system was composed of a pump, which can fill up the tank with a two-horse power gasoline engine. This was to raise the water from the reservoir to the tank. The delivery pump for the irrigation was a three-horse power gasoline engine with a low delivery rate to achieve low pressure. From the delivery pump to valve for pressure regulator, a suction hose was connected. To put this device to test, fifty minutes were taken to water a 220 square meter field. The water consumption was 500 gallons. Although this method was considered efficient at that time, it had a large size and the huge water consumption made it unsustainable.

Sinden *et al.* (2007) [9] made a traveling sprinkler with automatic water supply valve. The power supplied was by a twelve-volt battery positioned on the cart. In order to control the sprinkling system's cart, a programmable logic controller was used. The latter was responsible for the movement, speed and the sprinkler's operation. The cart had large rear drive wheels and two pairs of small front wheels. These wheels roll over the pipe placed on the field that provides a path for the cart.

Mehta *et al.* (2016) [10] constructed a prototype of mobile irrigation system by Arduino controlled algorithm to serve the agricultural sector. The vehicle was made to be controlled by an infrared remote control. It had a minimum range of 5 meters. Moreover, it utilized the ultrasonic sensors to avoid obstacles; this system was mostly manually controlled and had an automatic spray technique. It had an option for manual adjustment of the water spray intensity. The device movement was controlled via a microcontroller and DC motor.

Jianjun *et al.* [11], made a vehicle with a navigation control system that operates automatically. By using WLAN remote monitoring system, numerous tractors could be controlled. The monitoring system was connected to a GIS map, through it received information on every tractor's location. This vehicle was made to allow remote monitoring and automatic navigation control to provide control over several vehicles.

### III.1 The sprinkler system's drawbacks:

Climatic conditions such as wind speed and increase in temperature can result in altering the distribution pattern and increase in water evaporation rate respectively. Expensive labor force will be required to move and install the pipes for permanent sprinklers.

The amount of water being used in a traditional sprinkler system is more than required due to:

1. Overlapping range (Fig.2)
2. Location of nozzle
3. Uneven distribution of water

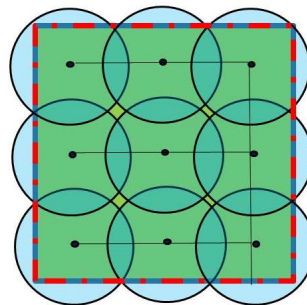

Fig.2 Demonstrating the overlapping range

## IV. ENHANCED SPRINKLER SYSTEM

From the various inventions shown, the proposed irrigation system will utilize similar components and additional ones to improve the overall usage. For example, there is the utilization of the solar panels that can

charge the battery, which will help in reducing electricity usage. An ultrasonic sensor will be used to avoid obstacles. Moreover, the technique of having a temporary water tank without the constant intervention of the user was not commercially popular. All of these factors can further enhance the water sprinkling system, which is capable of reducing the water consumption. The commercially available sprinklers' sizes are not efficient and awareness of using such a water-saving device is absent. This project aims to highlight the rising rates of water consumption and proposes a conceptually environment-friendly device which seeks to save water.

## IV.1 PROJECT DESCRIPTION

The proposed sprinkler device will combine the moving platforms feature with a portable water source. This system can be implemented in residential homes with a small to medium backyard. The proposed project description can be demonstrated as follows:

The ground moisture level can be detected by a moisture sensor, which will be positioned at the bottom of the device. The moisture sensor will be inserted into the ground temporarily then it will trigger the control circuit to activate the nozzles to spray water. A 12V DC rechargeable battery will be used for the motion of the motor and a sprayer pump with a driver (L298 Dual H-Bridge Motor Driver) should provide enough current for the pump. A servo and rotating platform will be used to spin the water flow as it leaves the nozzle. In order to transfer the water pipe to the desired area, the control will be made by Crowduino with ATmega and an Expansion Board to ease the connection. For the control of the spray distance, two servo motors will be used [12].

### A. Components description

#### A.1 Crowduino with ATmega 328

The Crowduino is a microcontroller board, which is based on the ATmega328. It has 14 digital input/output pins, 6 can be used as PWM outputs and 6 as analog inputs, and a USB connection and a power jack. It can be connected by a USB cable to the computer or with a battery. It has an Input voltage of 6-20V and a DC Current per I/O pin of 40 mA with a clock speed of 16 MHz.

#### A.2 Solar panel

The device that converts the light rays (photons) into electricity is the solar panel that consists of solar cells that are spread over a large area. It reaches full potential at places where the sun is strong because the more light rays that enter the cell, the more the production of electricity.

#### A.3 Motion

The DC motor (1to 2 HP) will be used to provide the device with enough power to travel through the lawn. Wheels containing studs will be installed to ease the traveling on a muddy surface.

#### A.4 Sensor

Two types of sensors are proposed to be used. The first sensor is capable of detecting soil conditions such as the level of moisture on the field. This will help to prevent the moist area from being watered twice. It can be programmed using an Arduino code. The code will include defined sensor pins, a variable to store the reading from the sensor to *the Crowduino*. After storing 5 readings, an average value can be taken and converted to a percentage. If the average value is lower than 28%, then the sprinkler will spray the water [13]. The ultrasonic sensor detects an object within a specified 3-meter diameter range, which is equivalent to the irrigation range. It is composed of an ultrasonic speaker, an optical reflective pair, and a microphone pair [14]. The sensor measures the round-trip time for a pulse to travel to an object and return back to the sensor. It utilizes the travel of acoustic waves and the calculation for the speed of sound to estimate the distance of an object. This helps to detect any

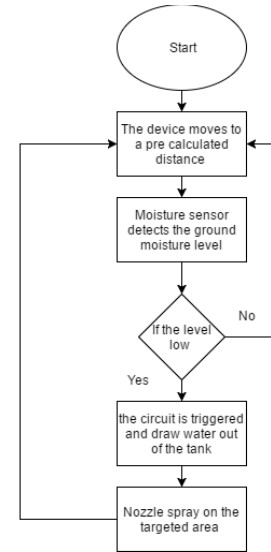

Fig. 3 Flowchart of the proposed system

potential obstacles such as a fence and thus reducing the sprinkler's flow rate to avoid objects based on these input ranges [15].

```
Moisture_monitor_program
/*
The program is for sampling the soil moisture to obtain a different values of different moisture

created 26 OCT. 2013
by Elecrow(www.elecrow.com)

This example code is in the public domain.

*/

//The moisture sensor pins definition
const int analogInPin0 = A0;
const int analogInPin1 = A1;
const int analogInPin2 = A2;

//The values obtained from each moisture sensor
int moistureValue0 = 0;      //the variable to store the moisture of the sensor1
int moistureValue1 = 0;      //the variable to store the moisture of the sensor1
int moistureValue2 = 0;      //the variable to store the moisture of the sensor1

//the sum of the 5 times sampling
long int moistureSum0 = 0;   // Moisture sampling will be taken 5 times to obtain average value
long int moistureSum1 = 0;
long int moistureSum2 = 0;
```



## SMART SPRINKLER SYSTEM

```

void setup() {
  // initialize serial communications at 9600 bps:
  Serial.begin(9600);
}

void loop() {
  // read the analog in value:

  for(int i = 0; i < 5; i++)//sampling for 5 time within 3 seconds
  {
    moistureSum0 = moistureSum0 + analogRead(analogInPin0);
    moistureSum1 = moistureSum1 + analogRead(analogInPin1);
    moistureSum2 = moistureSum2 + analogRead(analogInPin2);
    delay(100);
  }
  moistureValue0 = moistureSum0 / 30;// The average value
  moistureValue1 = moistureSum1 / 30;
  moistureValue2 = moistureSum2 / 30;

  // The result will be printed ona serial monitor
  Serial.print("Moisture0 = " );
  Serial.print(moistureValue0);
  Serial.print("\t Moisture1 = ");
  Serial.print(moistureValue1);
  Serial.print("\t Moisture2 = ");
  Serial.println(moistureValue2);
  Serial.println();

  moistureSum0 = 0;//reset the variable
  moistureSum1 = 0;
  moistureSum2 = 0;

  delay(4000);    //delay 4 seconds
}

```

Fig.4 The proposed Arduino code of moisture sensor

## B. Proposed specifications

### B.1 Watering calculation

In order to estimate the water amount required to water 100 square meter backyard, according to Jeddah municipality code the irrigation rate is 0.8 to 2.0 gallon/m<sup>2</sup>. This rate varies according to the weather conditions, type of soil and type of plant. The proposed pump has 1.05 HP thus a 30 psi would be sufficient as a good starting point for sprinklers [16].

The Formulas used:

- **Water Specifications:**

Area x Irrigation rate = 100 x 0.8= 80 gallon of water per day.

Table I Smart and Traditional sprinklers

Smart sprinkler system	Traditional sprinklers
Required amount of water + 10 % error	Required amount of water + 30 % error (overlapping and spillage)
88 gallons of water per day	104 gallons of water per day

- **Electricity Specifications:**

Table II Electricity specifications

Materials required	Specifications
DC Motor required for movement	2 HP =1492 W
Operating time	1.5 hours
Solar panel (30W-12V Monocrystalline)	30W
Battery	12V

## C. The proposed control circuit

The water input pipe will be plugged into the water tank and the other end to the pump's inlet. The water output pipe will be connected to the pump outlet; the other end will be fixed to the network of spraying nozzles. The pump will be connected to the outlet of the driver board.

The proposed connection of the Crowduino with the power supply and input ports of the driver are

Driver to the Crowduino  
 INC to the D6  
 IND to the D7  
 VCC to the VIN  
 GND to the GND

The Crowduino will be powered when connected to a 12V battery. The solar panel is connected to the battery and off-grid setup will be used to charge the battery. This requires a charge controller to be connected to the solar panel and battery. The solar panel will store the electricity into the battery then motion motor will function

accordingly [17]. The expansion board will be plugged into Crowduino, the moisture sensor will be connected to the Crowduino via the expansion board. The sensors will be connected to the analog ports (A0-A2). For the location of the target area for spraying, an adjustment of zero position is needed. Once the prototype is developed this code can be tested.

```

MedianValueSetting $
// Controlling a servo position using a potentiometer (variable resistor)
// by Michal Rinott <http://people.interaction-ivrea.it/m.rinott> |

#include <Servo.h>

Servo myservo1; // A servo object will be made to control the servo
Servo myservo2;

void setup()
{
  myservo1.attach(8); // the horizontal servo will be attached on pin 8 to the servo object
  myservo2.attach(9); // the vertical servo will be attached on pin 9 to the servo object
}

void loop()
{
  myservo1.write(93); // setting the median value of the servo
  myservo2.write(93);
}

```

Fig.5 The proposed control circuit for the servo motor

### A. Conceptual design

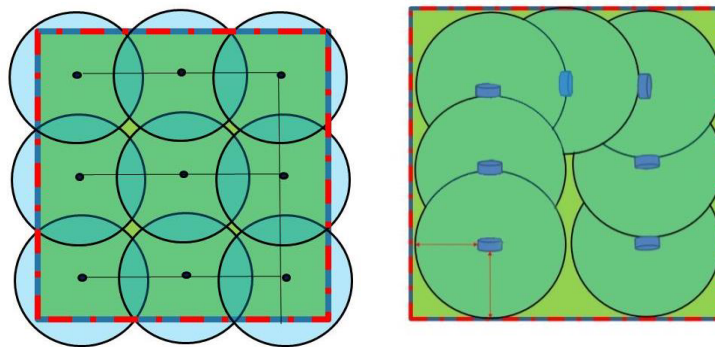

(a) Traditional (b) Enhanced  
Fig.6 Traditional vs. Enhanced sprinklers

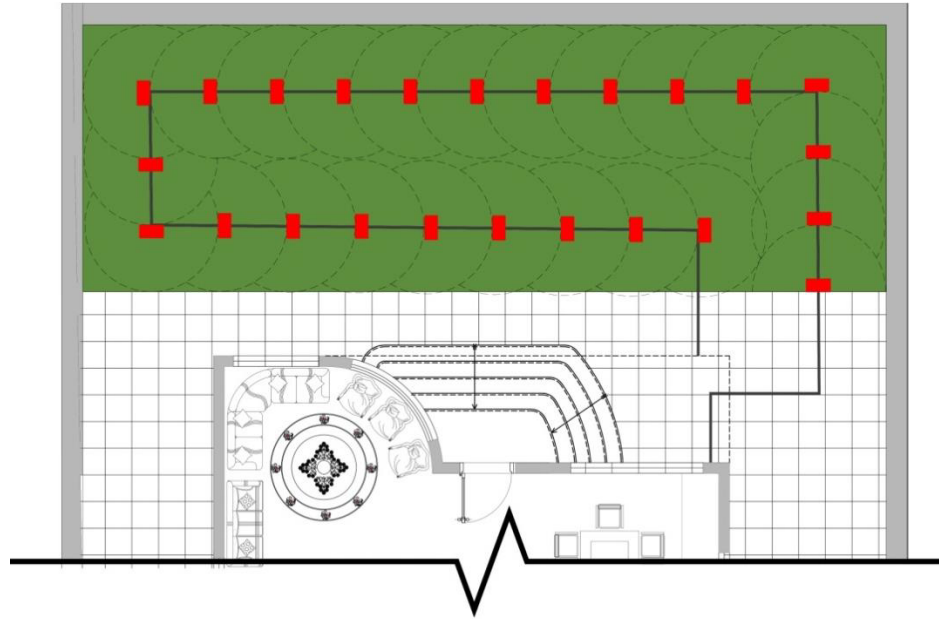

Fig. 7 Example of traveling sprinkler route

For optimal usage, the dimension of the required area to be watered will be entered in the software program using the push buttons on the top of the device. The algorithm will determine the range of the water spread. The range of water can be manipulated to eliminate missed spots, depending on the size of the land. Once put on the site, the object sensor will sense the location of the sidewalk or fence to prevent any spillage outside the grass area. It will move and irrigate the area according to the calculated distance. The software program will act as an interface between the device and the Arduino code. The Arduino code will entail initialization and defining of the moisture pin and the servo position (to determine the position of the fence), and specifying the watering time by a constant value and specify the water pump control pins etc. Using the IF function, a decision will be made that if moisture value is lower than 28%, it will trigger the circuit and water the targeted area.

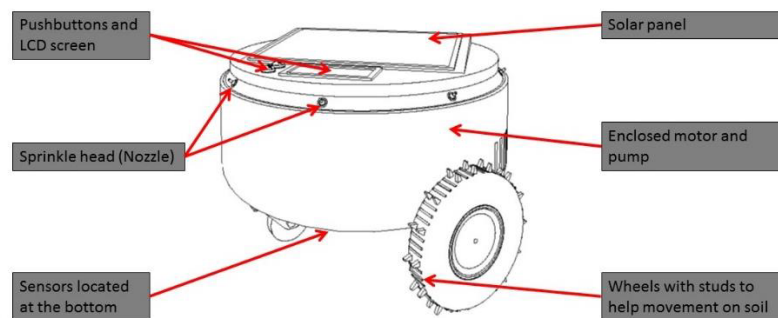

Fig.8 Illustration of the product design

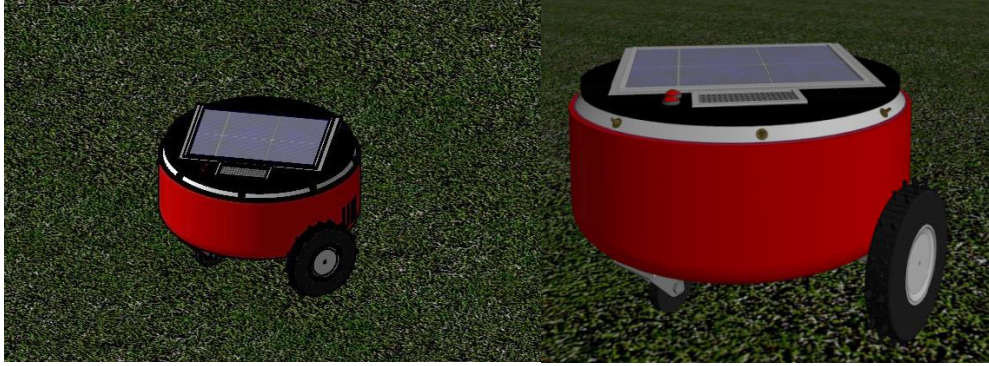

Fig.9 3D visualization of the product

## V. CONCLUSION

This project is still under development. With further progression and code testing, we can get more concrete results and values. The enhanced water sprinkling system is able to save approximately 16 gallons of water, which is 15% more than the traditional sprinklers. Using a solar panel on the top of the device can increase the surface area to receive the sunlight. This makes it efficient to be used in a sunny and dry area. The expected obstacles can be: choosing suitable nozzle to handle the water pressure and building a suitable software program. Although it is expensive to buy, it will have a long run benefit saving in water usage as well as reducing the drainage required. This is highly beneficial, since the water wasted in large amount makes the grass susceptible to diseases and insects. Since the smart sprinkler device is capable of providing sufficient amount of water required by the grass, it prevents the need for a drainage pipe to get rid of the excess water. This makes us one-step closer to reaching the 2030 vision.

In order to improve this device, some improvements have to be looked upon:

- The range of the distance sensor can be further increased to cover wide areas like farms.
- The buttons can be replaced with a touch screen to make it more user-friendly.

## REFERENCES

- [1] imos (2016, October 12). "Importance of water in our life". Available: <http://importanceofstuff.com/water>
- [2]. W. A. Abderrahman (2006, December), "Groundwater Resources Management in Saudi Arabia", *Special Presentation and Water Conservation Workshop*, Available: <http://sawea.org/pdf/FutureOfSaudiArabianWaterAquifers.pdf>.
- [3]. O. K. Ouda, "Towards Assessment of Saudi Arabia Public Awareness of Water Shortage Problem", *Resources and Environment*, vol. 3, issue 1, pp. 10-13, 2013, Available:  
[http://www.pmu.edu.sa/kcfinder/upload/files/Towards\\_Assessment\\_of\\_Saudi\\_Arabia\\_Public\\_Awareness\\_of\\_Water\\_Shortage\\_Problem.pdf](http://www.pmu.edu.sa/kcfinder/upload/files/Towards_Assessment_of_Saudi_Arabia_Public_Awareness_of_Water_Shortage_Problem.pdf).
- [4] S. AL-SUGHAIR, (2016, February 13), "KSA's water consumption surpasses global average", *Arab News*, Available:  
<http://www.arabnews.com/saudi-arabia/news/879801>
- [5] Saudi Vision 2030 (2016, April 16), *Saudi Arabia's Vision 2030, Achieving Environmental Sustainability*, Available:  
<http://vision2030.gov.sa/en/node/10>
- [6] P. Claude (1970), *Sprinkler Irrigation* [Brochure], Available:  
<https://eprints.nwisrl.ars.usda.gov/1134/1/205.pdf>
- [7] Jain Irrigation system Ltd. Products (2014), "Sprinkler Irrigation Systems", Available:  
<http://www.jains.com/irrigation/popups%20and%20sprinklers/sprinklersystems.htm>
- [8] G. Garcia (1979), *A portable irrigation system for remote sites*, Available:  
<https://play.google.com/books/reader?id=cm2aCaoT56oC&printsec=frontcover&output=reader&hl=en&pg=GBS.PP1&pg=GBS.PP1>
- [9] J. Sinden, R. Ness, C. Leinweber, R. Berrier, C. Nelson & B. Nelson (2007), *Traveling sprinkler incorporating automatic water supply valve docking station*, Available: <https://www.google.com/patents/US7300004>
- [10] U. Mehta, P..Chand, K. A..Mamun, S. Kumar, V. Chand, N. Chand and H. Komaitai (2016, May 23), "Designing of a mobile irrigation system", Available: <http://ieeexplore.ieee.org/document/7476237/>
- [11] Z.Jianjun, C. Min'gang, Z. Man.and L.Su, "Remote Monitoring and Automatic Navigation System for Agricultural Vehicles Based on WLAN", *4th International Conference on Wireless Communications, Networking and Mobile Computing*, Dalian, 2008.
- [12] Elecrow (2017, March 26), "Arduino Automatic Watering System for Plants Sprinkler", Available:  
<http://www.instructables.com/id/Arduino-Automatic-Watering-System-For-Plants/>
- [13] Dynamax, Inc. (n.d.). "TH2O Soil Moisture Meter". Available: [ftp://ftp.dynamax.com/Turf\\_Irrigation/th2o.pdf](ftp://ftp.dynamax.com/Turf_Irrigation/th2o.pdf)
- [14] MODMYPI LTD (2015, September 11). "HC-SR04 Ultrasonic Range Sensor on the Raspberry Pi", Available:  
<https://www.modmypi.com/blog/hc-sr04-ultrasonic-range-sensor-on-the-raspberry-pi>
- [15] J. Frank, B. Tai, & Y. Shnirman (2009, May 1), "Final Project Report", Polytechnic Institute of NYU, Available:  
[http://engineering.nyu.edu/mechatronics/projects/ME3484/Spring%202009/Autonomous%20Sprinkler%20System%20with%20Object%20Avoidance/Mechatronics\\_Report\\_FINAL.pdf](http://engineering.nyu.edu/mechatronics/projects/ME3484/Spring%202009/Autonomous%20Sprinkler%20System%20with%20Object%20Avoidance/Mechatronics_Report_FINAL.pdf)
- [16] SODCO (n.d), "Reasons why you shouldn't overwater your lawn or turf - lawn care tips from Sodco", Available:  
<http://www.sodco.net/tips-and-resources/overwatering>
- [17] Power, Qualitative Reasoning Group. (n.d.). Available:  
<http://www.qrg.northwestern.edu/projects/vss/docs/power/1-what-are-solar-panels.html>